

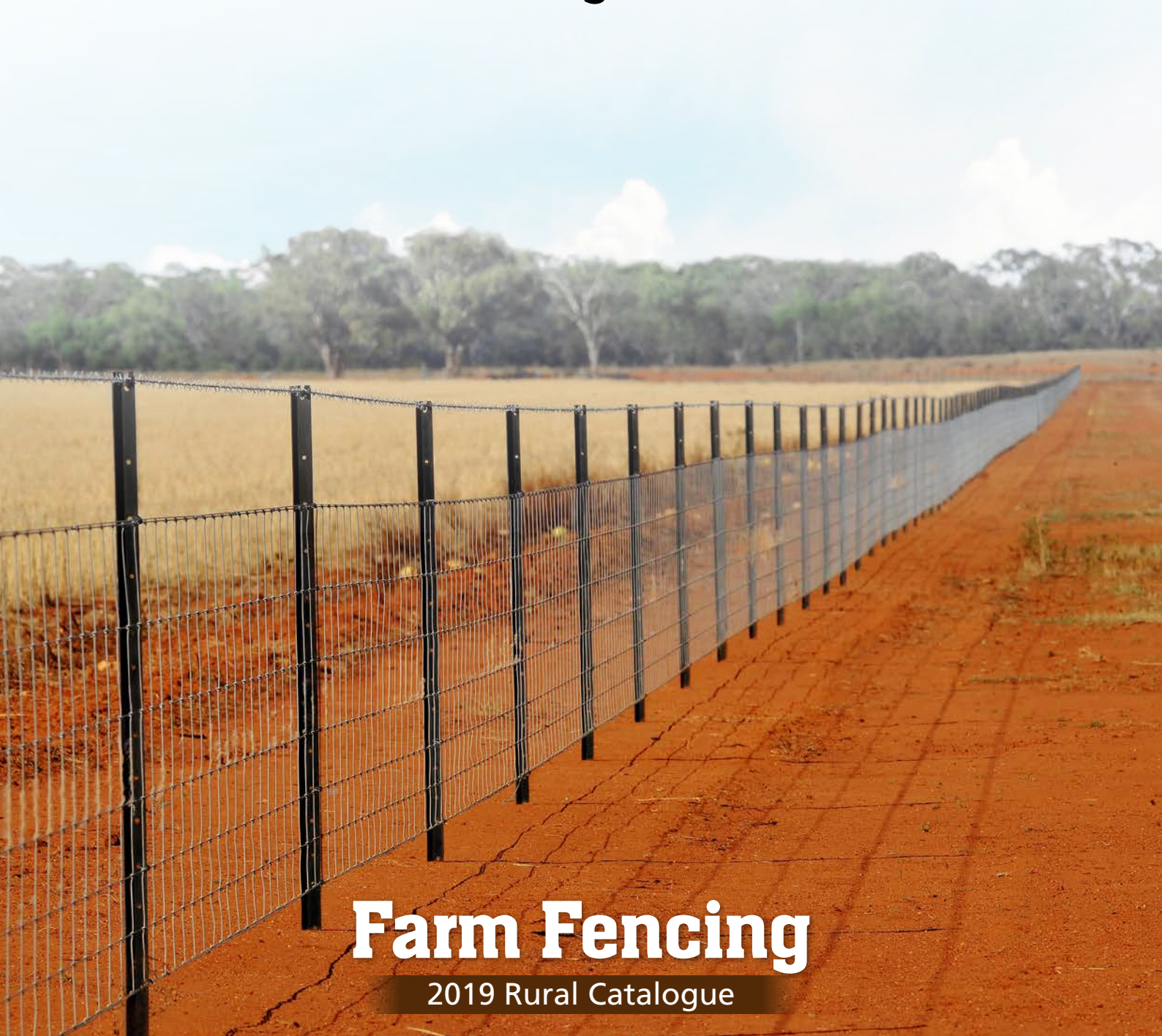

Posts • Fencing • Gates • Tools



Farm Fencing

2019 Rural Catalogue

www.whitesrural.com.au ↗



Posts • Fencing • Gates • Tools

Australian family owned, down to earth, no nonsense

Whites Group has been listening and responding to the needs of Australian farmers and fencing contractors for over 40 years. Continuously developing better fencing ideas proven to work on the farm, Whites Group has pioneered a number of original ideas like Stockpost Ute Pack, designed to get the job done with a minimum of fuss.

Australian owned and operated, Whites Group is a family business with its roots strongly embedded in steel, wire and fencing products since 1977. Today, Whites Rural takes up the mantle as Whites Group's specialist rural arm signifying a deeper, long-term commitment to the needs of rural Australia.

A celebratory logo for 40 years. The number "40" is large and bold, with a wheat stalk icon to its left. The word "Years" is written in a smaller font to the right of the "0". A second wheat stalk icon is to the right of "Years". The entire graphic is set against a dark brown background with a white outline.

Australian Family Owned

www.whitesrural.com.au



FARM FENCING

Rural Catalogue



STOCKPOST

the mark of a good post

Stockpost®	4
Stockpost® Ute Pack®	5
Droppers	5
Stockpost® XL	6
Stockpost® End Assembly	7
Stockpost® Anti-Sink Plate	7

FENCING

Fence Wire	8
Barbed Wire	9
Horse Sight Fence Wire	9
Stiff Knot® Prefabricated Fencing	10-11
Stiff Stay® Prefabricated Fencing	12-14
Hinged Joint	15
Heavy Netting	16
Farm Mesh	17
Welded Mesh	18
Horticulture	19

GATES & FITTINGS

Farm Gates	20-21
Frauenfelder Farm Gates	22-23
Frauenfelder Specialty Farm Gates	24
Ballimore & Feral Farm Gates	25
Gate Fittings	26-27

TOOLS

Drivers, Lifters & Wire Spinners	28
Strainers	29
Stapling	30-31
Fastening	32
MaxTensor®	33
Accessories	34
Farm Pak™ Tie Wires	34

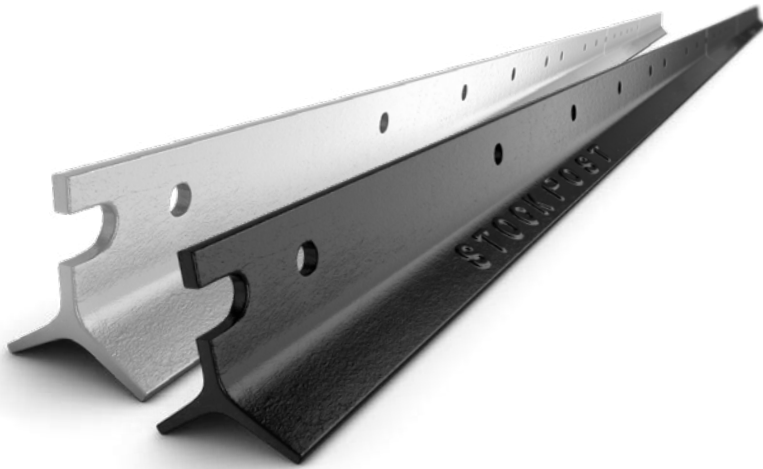

STOCKPOST®

Trusted, tried & true.

Consistently rolled from specially produced high grade steel, Stockpost is a premium fence post – strong and reliable.

- ✓ High strength, high consistency
- ✓ Coatings that withstand the test of time
- ✓ Innovative ground mark
- ✓ Hole alignment that's straight up
- ✓ Easy to drive

Stockpost is available in black bituminous dipped coating, providing a tough outer barrier, or hot-dipped galvanised to meet the Australian Standards for optimum protection.

Featuring consistent ground marks and centre marks for accurate height positioning; precision hole alignment & spacing for a uniform fence from the first to the last post; and uniformly cut end-points to drive in straight and easy.

- Australian Innovation
- Engineered for Consistency • Coatings that Last



Hole Spacing

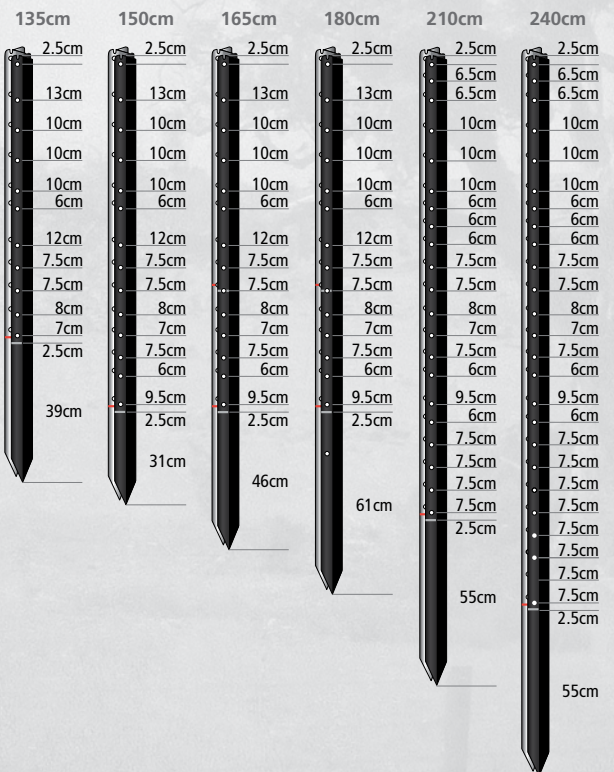

Code	Product	Size (ft)	Sling Qty	Weight (each)	Coating
STOCKPOST® - BLACK BITUMINOUS					
10804	135cm STOCKPOST	4'6"	400	2.6kg	Black
10807	150cm STOCKPOST	5'	400	2.8kg	Black
10805	165cm STOCKPOST	5'6"	400	3.1kg	Black
10806	180cm STOCKPOST	6'	400	3.4kg	Black
10809	210cm STOCKPOST	7'	200	4.0kg	Black
10808	240cm STOCKPOST	8'	200	4.6kg	Black
STOCKPOST® - HOT-DIPPED GALVANISED					
10814	135cm STOCKPOST	4'6"	200	2.6kg	Galvanised
10817	150cm STOCKPOST	5'	200	2.8kg	Galvanised
10815	165cm STOCKPOST	5'6"	200	3.1kg	Galvanised
10816	180cm STOCKPOST	6'	200	3.4kg	Galvanised
10819	210cm STOCKPOST	7'	200	4.0kg	Galvanised
10818	240cm STOCKPOST	8'	200	4.6kg	Galvanised

STOCKPOST®

the mark of a good post

STOCKPOST® UTE PACK®

Australian designed Ute Pack - Stockpost quality & features in a contractor pack.

200 Stockposts in a secure steel cradle... and no tie wires!



Effortless Handling

Packed as singles.
No bundle ties.



Easy Load Pack

Front-end loader and ute friendly.



Fast & Efficient

Get it onto the ute and into the ground.



Refastenable Pack

Use some or all, posts stay secure.



Australian Design

Designed & patented in Australia, for Australian farmers.



Stronger, Longer, Further
...just got *FASTER!*

Code	Product	Size (ft)	Sling Qty	Weight (each)	Coating
STOCKPOST® - BLACK BITUMINOUS					
10801	165cm STOCKPOST - UTE PACK	5'6"	200	3.1kg	Black
10802	180cm STOCKPOST - UTE PACK	6'	200	3.4kg	Black
10803	225cm STOCKPOST - UTE PACK	7'6"	200	4.3kg	Black
STOCKPOST® - HOT DIPPED GALVANISED					
10811	165cm STOCKPOST - UTE PACK	5'6"	200	3.1kg	Galv
10812	180cm STOCKPOST - UTE PACK	6'	200	3.4kg	Galv
10810	225cm STOCKPOST - UTE PACK	7'6"	200	4.3kg	Galv

DROPPERS

Whites Rural Fence Droppers are manufactured from high grade steel and heavily galvanised to ensure long life.

Use with barbed wire or plain wire.

- Manufactured from high tensile steel
- Heavily galvanised for long life
- Pack of 25 includes tool and clips



Code	Product	Sling Qty	Weight (each)	Coating
STEEL FENCE DROPPERS				
10510	63.5cm Droppers	25	6kg	Hot Dip Galvanised
10511	81.5cm Droppers	25	9.4kg	Hot Dip Galvanised
10512	94cm Droppers	25	10.6kg	Hot Dip Galvanised
10514	107cm Droppers	25	12.2kg	Hot Dip Galvanised
10515	117cm Droppers	25	13.3kg	Hot Dip Galvanised
10516	Dropper Clips 500gm	-	-	-



STOCKPOST® XL

Meet Stockpost's **BIG** brother.

Stockpost XL is hot rolled from the same quality raw material as Stockpost, so you know it's good.

SMARTER

3 equal fins for all around stability and more holes per post (ideal for feral fencing). A great alternative to timber posts.

FASTER

Packed in a faster fencing Ute Pack sling for easy access, easy handling.
4:1 ratio – 200 Stockposts plus 50 Stockpost XLs provides a typical fencing ratio.

STRONGER

Hot rolled from the same quality raw material as Stockpost, independently NATA tested.

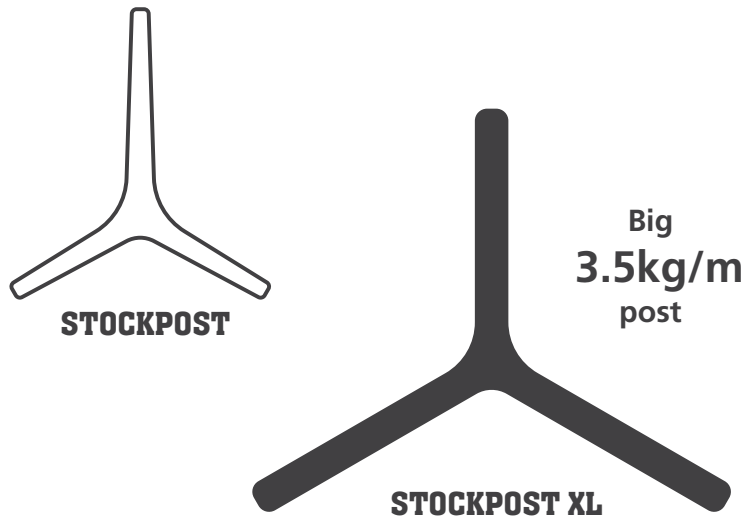

Hole Spacing

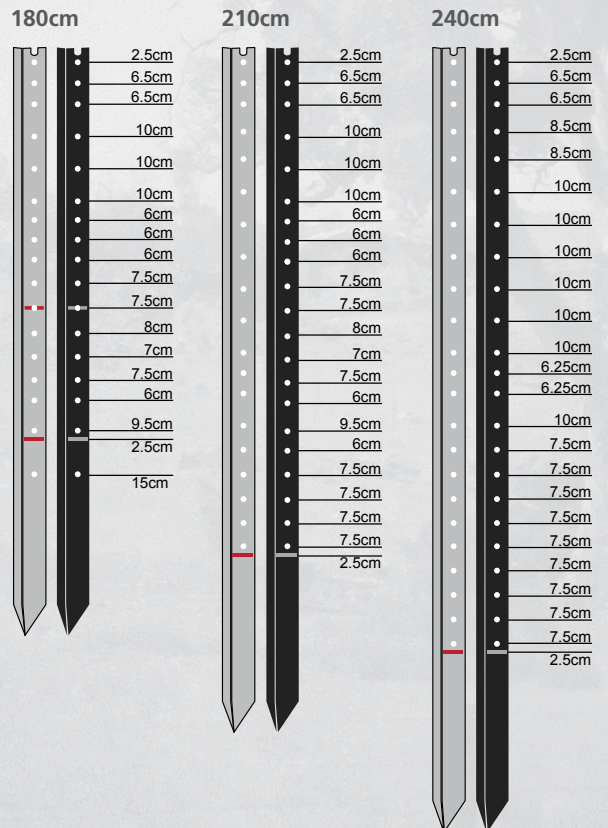

Code	Product	Size (ft)	Sling Qty	Weight (each)	Coating
STOCKPOST® - BLACK BITUMINOUS					
10846	180cm STOCKPOST XL	6'	50	6.3kg	Black
10849	210cm STOCKPOST XL	7'	50	7.4kg	Black
10848	240cm STOCKPOST XL	8'	50	8.4kg	Black
STOCKPOST® - HOT-DIPPED GALVANISED					
10856	180cm STOCKPOST XL	6'	50	6.3kg	Galvanised
10859	210cm STOCKPOST XL	7'	50	7.4kg	Galvanised
10858	240cm STOCKPOST XL	8'	50	8.4kg	Galvanised

STOCKPOST® END ASSEMBLY

A fully hot-dipped galvanised end assembly system made with Stockpost quality, for high performance without the high price tag.

Featuring a heavy duty square steel Anchor Post with unique shark tooth points that cleverly cut through soil to avoid compaction for effortless driving. Each Anchor Post includes a steel cap and the Stockpost ground mark for easy fence line up at ground level.

- Time saving & easy installation
- Fully hot-dipped galvanised
- Heavy duty registered design

The Stay Assembly Kit includes a 3m brace pipe with specially designed brace cap for ease of installation; a heavy duty fire-proof base plate; and a notched threaded rod for easy tensioning.

The Stockpost End Assembly range also includes gate fittings and additional brace caps for 2, 3, and 4-way configurations.

			
fireproof base plate	fully hot-dipped galvanised	"shark tooth" registered design	innovative ground mark
			
heavy duty square post	pre-drilled holes & multiple configurations	heavy duty brace cap	clever edges to avoid compaction

STOCKPOST® ANTI-SINK PLATE

Stabilise steel fence posts in soft or loose soils. The surface area of the wide base guards against sinking and limits movement. Simply attach at ground level using the steel locking pin. Easily retro-fitted to existing fences.

- High strength, galvanised steel
- Large 15cm base, greater support
- Suits Stockpost and Stockpost XL and most other steel "Y" posts



ground-breaking technology

Code	Product	Pack Qty	Weight (each)
STOCKPOST® - END ASSEMBLY SYSTEM			
10870	STOCKPOST Anchor Post 2.1m	5	22.5kg
10875	STOCKPOST Stay Assembly 3m	5	17.1kg
STOCKPOST® - END ASSEMBLY ACCESSORIES			
10876	STOCKPOST Brace Cap with Spike	10	0.5kg
10877	STOCKPOST Base Plate	2	6.5kg
13855	End Assembly Gate Fitting Top Strap & Gudgeon	5	2.4kg
13856	End Assembly Gate Fitting Drop Latch & Eyelet	5	1kg



Code	Product	Pack Qty	Weight (each)
STOCKPOST® - ANTI-SINK PLATE			
12218	STOCKPOST Anti-Sink Plate	20	0.2kg



Meets Australian Standards

Code	Wire	Tensile Strength	Coil Length	Coil Weight	Sling Qty	Galv. Coating	Rec. Tension Breaking Strain
HEAVILY GALVANISED FENCE WIRE							
10014	2.50mm	Medium	1500m	58kg	10	Heavy	1.3kn, 3.7kn
10015	2.50mm	High	1500m	58kg	10	Heavy	1.8kn, 5.4kn
10016	2.80mm	High	1000m	48kg	10	Heavy	2.0kn, 6.8kn
10017	3.15mm	Soft	750m	46kg	10	Heavy	1.2kn, 3.0kn
10018	4.00mm	Soft	500m	50kg	10	Heavy	1.8kn, 4.8kn
STANDARD GALVANISED FENCE WIRE							
10161	4.00mm	Soft	500m	49kg	10	Standard	1.8kn, 4.8kn
10163	3.15mm	Soft	750m	46kg	10	Standard	1.2kn, 3.0kn
10170	2.50mm	Medium	1500m	58kg	10	Standard	1.3kn, 3.7kn
10171	2.50mm	High	1500m	58kg	10	Standard	1.8kn, 5.4kn
STANDARD GALVANISED TIE WIRE							
10164	2.50mm	Soft	1300m	50kg	10	Standard	1.3kn, 3.7kn
10165	2.00mm	Soft	2000m	50kg	10	Standard	-
10166	1.57mm	Soft	3200m	50kg	10	Standard	-



Code	Wire	Tensile Strength	Coil Length	Coil Weight	Sling Qty	Galv. Coating	Rec. Tension Breaking Strain
HANDYFENCE™							
10011	2.50mm	Medium	300m	11.6kg	10	Standard	1.3kn, 3.7kn
10012	3.00mm	Soft	250m	13.9kg	10	Standard	1.2kn, 3.0kn

FENCING

FENCE WIRE
Heavily & Standard Galv.

RURAL FENCE WIRE

Whites Rural Heavily Galvanised and Standard Galvanised Rural Fence Wire are made to the highest standards, exclusively from Frauenfelder's Albury plant in regional Australia, using premium grade wire.

Heavily Galvanised

Heavily Galvanised to last up to four times longer than standard galvanising.

Standard Galvanised

Standard Galvanised Fence Wire and Tie Wire are economical fencing options, with a quality you can trust.

- Soft - easy to handle and tie
- Medium Tensile - ideal with prefab fencing
- High Tensile - suited to longer strains

The wire is recoiled on new machines to provide smooth & tangle free delivery off the wire spinner, saving contractors and farmers expensive down time. Produced on the latest, highest tolerance recoilers to electronically deliver full and accurate details for each coil of wire.



HANDYFENCE™

Whites Rural Handyfence coils, a great option for smaller fencing runs or for quick and easy repairs to fences.

FENCE WIRE

Barbed & Specialty Wires



BARBED WIRE

Whites Rural Barbed Wire is made to the highest standards, exclusively from Frauenfelder's Albury plant in regional Australia, using premium grade wire.

Produced on new machines which are the latest and highest tolerance barbed wire machines available today, the bars are tightly twisted to prevent them from slipping out of position. All barbed wires are supplied rolled on hardwood timber reels.

High Tensile Barbed Wire

Reverse twist style for optimum strength & tensioning.

IOWA Barbed Wire

IOWA continuous-twist style.



Meets Australian Standards

Code	Wire	Tensile Strength	Coil Length	Coil Weight	Pallet Qty	Galv. Coating	Rec. Tension Breaking Strain
HIGH TENSILE BARBED WIRE							
10100	2.00mm	High	500m	37kg	36	Heavy	1.6kn, 5.0kn
10101	1.80mm	High	500m	28kg	36	Heavy	1.3kn, 4.0kn
10102	1.57mm	High	500m	24kg	48	Heavy	1.3kn, 3.0kn
IOWA BARBED WIRE							
10150	2.50mm	Soft	400m	45kg	27	Standard	1.3kn, 3.0kn
10151	2.50mm	Soft	400m	45kg	27	Heavy	1.3kn, 3.0kn

HORSE SIGHT FENCE WIRE

Used as a top wire on horse fencing to increase visibility and prevent injury to horses.

- White PVC coating improves visibility
- Reduces damage to fences and injury to horses
- UV stabilised PVC coating



*5.2mm total diameter including PVC coating

Code	Wire	Tensile Strength	Coil Length	Coil Weight	Sling Qty	Galv. Coating	Rec. Tension Breaking Strain
HORSE SIGHT FENCE WIRE							
10169	5.2mm*	Soft	400m	43kg	5	Standard	2.0kn, 6.0kn

STIFF KNOT®

PREFABRICATED FARM FENCING



FENCING

STIFF KNOT

Prefabricated Fencing

STIFF KNOT®

Stiff Knot prefabricated fencing is manufactured in Australia on the fixed knot machine. The name Stiff Knot is trademarked to Whites and made exclusively by Frauenfelder, Whites' manufacturing partner, based in Albury NSW.

Stiff Knot is a large fixed knot that rigidly locks line wires to one-piece vertical pickets.

Considered the strongest knot available, it provides maximum strength by absorbing impact and spreading the load.

No exposed ends which can snag livestock. Available with optional hinged apron.



FARM FENCING

Manufactured to Australian Standards AS 2423-2002 and zinc coated to AS/NZS 4534-2006.

Heavily Galvanised Stiff Knot features high tensile 2.8mm line wires at top and bottom; 2.5mm high tensile line wires with graduated spacings; 2.5mm vertical stay wires.

Spacing Chart

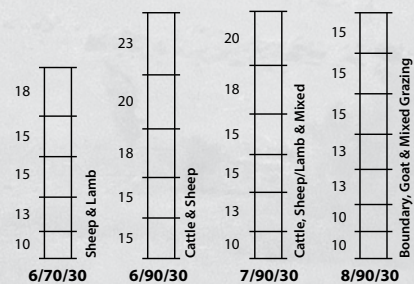

Heavily Galv. Code (Weight)	Product	Roll Length	Tensile Strength	Pallet Qty
STIFF KNOT® FARM FENCE				
A0348 (70kg)	5/70/30	200m	High	9
10331 (80kg)	6/70/30	200m	High	9
A0335 (162kg)	6/70/30	400m	High	4
10332 (85kg)	6/90/30	200m	High	9
A0336 (171kg)	6/90/30	400m	High	4
A0382 (73kg)	6/90/45	200m	High	9
10333 (96kg)	7/90/30	200m	High	9
A0337 (193kg)	7/90/30	400m	High	4
A0384 (83kg)	7/90/45	200m	High	9
10334 (106kg)	8/90/30	200m	High	9
A0339 (213kg)	8/90/30	400m	High	4



STIFF KNOT

Exclusion Fencing



EXCLUSION FENCING

Narrow 15cm picket spacings for smaller animals and exclusively manufactured by Frauenfelder in Albury NSW, Stiff Knot exclusion fencing features:

Premium Coating & Wire Grade

- Heavily Galvanised
- 2.8mm high tensile top and bottom line wires
- 2.5mm high tensile line wires and 2.5mm vertical stay wires

Continuous Vertical Pickets

- Stiff Knot features continuous vertical pickets which are locked into place to resist sagging & buckling
- Compared to hinged joint fencing, they also provide a better fence over undulating land following the contour of the ground

Optional Pre-attached Hinged Apron

- Pre-attached to the bottom line wire with a hinged joint, the apron is a 300mm section of fence laid on the ground, restricting penetration or digging under the fence
- Exclusion fencing without hinged aprons require the fencing to be forced onto the ground, placing unnecessary stress on your fence posts
- The hinged version is both faster to install and easier on the fence, giving it a longer service life
- Also referred to as a hinged footer

Pre-Stripped Roll

- Stiff Knot has the first two pickets and the last two pickets removed from every roll
- A convenient aid for faster installation around end assemblies - no need to strip picket wires

Tension Crimps

- Stiff Knot line wires include tension crimps that provide a quick visual when judging the correct tension
- When the crimp is half flattened, the tension is generally sufficient; when no crimp can be seen, then the tension in the wire is too high and needs to be reduced

Spacing Chart

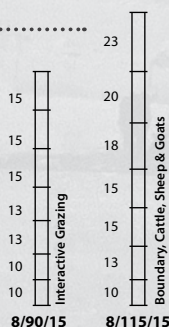

Also available as apron only for fitting to existing fences.



Heavily Galv. Code (Weight)	Product	Hinged Apron	Roll Length	Tensile Strength	Pallet Qty
STIFF KNOT® EXCLUSION FENCE					
10338 (74kg)	8/90/15		100m	High	9
A0367 (101kg)	8/90/15	30cm 3-line	100m	High	9
A0341 (144kg)	8/90/15		200m	High	4
A0368 (202kg)	8/90/15	30cm 3-line	200m	High	4
A0389 (93kg)	11/90/15		100m	High	9
A0385 (127kg)	11/90/15	30cm 4-line	100m	High	9
A0351 (106kg)	13/90/15		100m	High	9
A0355 (133kg)	13/90/15	30cm 3-line	100m	High	9
10339 (80kg)	8/115/15		100m	High	9
A0370 (107kg)	8/115/15	30cm 3-line	100m	High	9
A0340 (161kg)	8/115/15		200m	High	4
A0371 (215kg)	8/115/15	30cm 3-line	200m	High	4
A0372 (254kg)	11/115/15	30cm 3-line	200m	High	4
10359 (113kg)	13/115/15		100m	High	9
A0373 (140kg)	13/115/15	30cm 3-line	100m	High	9
A0358 (266kg)	13/115/15		200m	High	4
A0374 (280kg)	13/115/15	30cm 3-line	200m	High	4
A0380 (118kg)	13/137/15		100m	High	9
A0378 (145kg)	13/137/15	30cm 3-line	100m	High	9
A0383 (237kg)	13/137/15		200m	High	4
A0379 (291kg)	13/137/15	30cm 3-line	200m	High	4
A0386 (298kg)	13/150/15	30cm 3-line	200m	High	4
10360 (134kg)	15/150/15		100m	High	9
A0376 (162kg)	15/150/15	30cm 3-line	100m	High	9
A0361 (270kg)	15/150/15		200m	High	9
A0377 (324kg)	15/150/15	30cm 3-line	200m	High	9
A0363 (343kg)	16/160/15	30cm 3-line	200m	High	9
A0365 (168kg)	19/180/15		100m	High	9



FENCING

STIFF STAY

Prefabricated Fencing

STIFF STAY

PREFABRICATED FARM FENCING

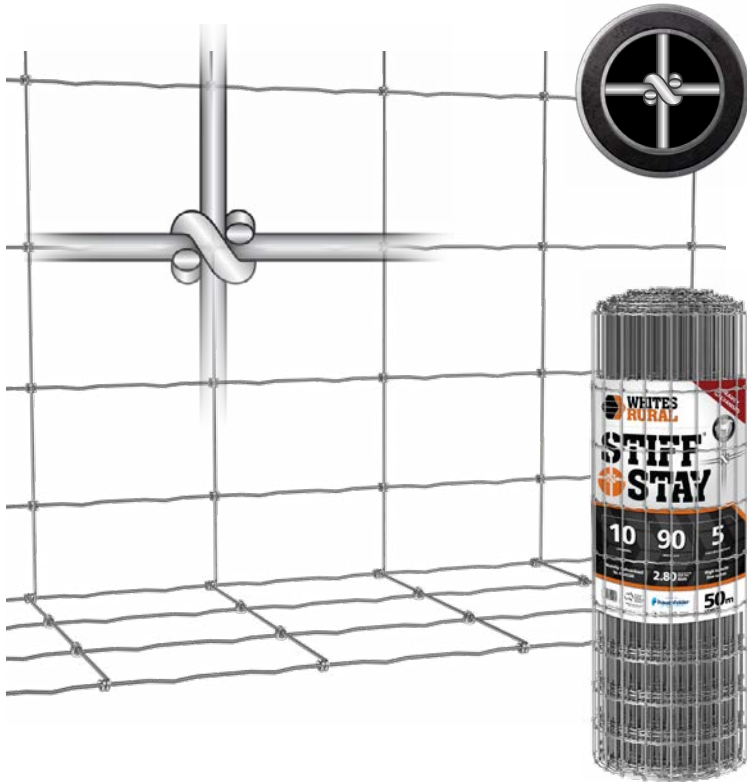

STIFF STAY®

Stiff Stay prefabricated fencing features a tight cross-over knot manufactured on the Stiff Stay machine. The name Stiff Stay is trademarked to Whites and made exclusively by Frauenfelder, Whites' manufacturing partner, based in Albury NSW.

The Stiff Stay knot locks the wires in place to resist buckling and sagging. The shape of the knot provides a smooth surface so it is safe and easy to use.

- ✓ Heavily galvanised for longer life
- ✓ Tight cross-over knot
- ✓ Resists buckling and sagging
- ✓ Smooth, safe and easy to use
- ✓ High tensile line wires
- ✓ 2.80mm top & bottom wires
- ✓ Available in rolls up to 500m

HORSE FENCE

Whites Rural Stiff Stay Fabricated Horse Fence is specifically designed to be safer for horses. The tight 5cm picket spacings provide safety from hoof and leg tangling, minimising injuries to horses.

- Smooth clean knot prevents injury to horses
- Smaller aperture mesh
- Resists buckling and sagging

Made to the highest standards using premium grade wire.

Heavily Galvanised features high tensile 2.8mm line wires at top and bottom; 2.5mm high tensile line wires & 2.5mm vertical stay wires.

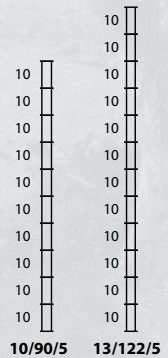

Heavily Galv. Code (Weight)	Product	Roll Length	Tensile Strength	Pallet Qty
STIFF STAY® HORSE FENCE				
10264 (68kg)	10/90/5	50m	High	9
10256 (93kg)	13/122/5	50m	High	9



STIFF STAY

Prefabricated Fencing



FARM FENCING

Manufactured to Australian Standards AS 2423-2002 and zinc coated to AS/NZS 4534-2006.

Heavily Galvanised Stiff Stay features high tensile 2.8mm line wires at top and bottom; 2.5mm high tensile line wires with graduated spacings; 2.5mm vertical stay wires.

Also available in Standard Galvanised with 2.5mm top and bottom line wires.

Spacing Chart

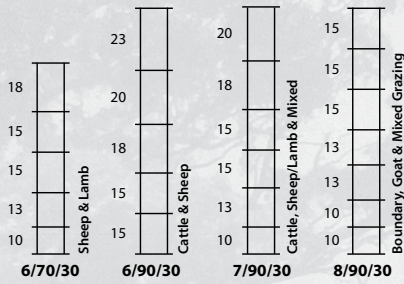

Heavily Galv. Code (Weight)	Standard Galv. Code (Weight)	Product	Roll Length	Tensile Strength	Pallet Qty
STIFF STAY[®] FABRICATED FARM FENCING					
10231 (72kg)	A0201 (68kg)	6/70/30	200m	High	9
A0261 (180kg)	A0221 (170kg)	6/70/30	500m	High	4
A0280 (65kg)		6/70/45	200m	High	9
A0281 (161kg)	A0224 (150kg)	6/70/45	500m	High	4
10232 (78kg)		6/90/30	200m	High	9
A0262 (195kg)		6/90/30	500m	High	4
A0282 (68kg)		6/90/45	200m	High	9
A0283 (63kg)		6/90/60	200m	High	9
10233 (86kg)	A0203 (81kg)	7/90/30	200m	High	9
10263 (215kg)	A0223 (202kg)	7/90/30	500m	High	4
A0284 (76kg)		7/90/45	200m	High	9
A0285 (190kg)	A0225 (178kg)	7/90/45	500m	High	4
A0286 (71kg)		7/90/60	200m	High	9
A0287 (91kg)		8/80/30	200m	High	9
10234 (94kg)	A0204 (89kg)	8/90/30	200m	High	9
A0265 (235kg)	A0264 (224kg)	8/90/30	500m	High	4
10261 (101kg)		8/115/30	200m	High	9

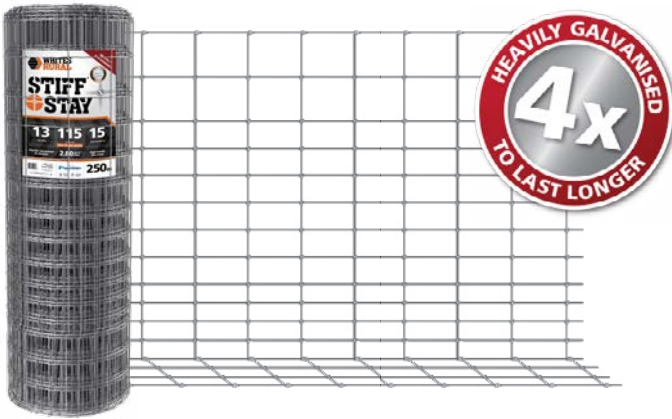

Available with a 30cm hinged apron, for an effective barrier at ground level



Heavily Galv. Code (Weight)	Product	Hinged Apron	Roll Length	Tensile Strength	Pallet Qty
STIFF STAY® EXCLUSION FENCE					
10235 (62kg)	8/80/15		100m	High	9
10238 (63kg)	8/90/15		100m	High	9
A0267 (84kg)	8/90/15	30cm 3-line	100m	High	9
A0266 (156kg)	8/90/15		250m	High	4
A0268 (209kg)	8/90/15	30cm 3-line	250m	High	4
10289 (76kg)	11/90/15		100m	High	9
10285 (97kg)	11/90/15	30cm 4-line	100m	High	9
10251 (86kg)	13/90/15		100m	High	9
10255 (106kg)	13/90/15	30cm 3-line	100m	High	9
10239 (69kg)	8/115/15		100m	High	9
A0270 (90kg)	8/115/15	30cm 3-line	100m	High	9
A0269 (172kg)	8/115/15		250m	High	4
A0271 (225kg)	8/115/15	30cm 3-line	250m	High	4
A0390 (258kg)	11/115/15	30cm 3-line	250m	High	4
10259 (92kg)	13/115/15		100m	High	9
A0273 (140kg)	13/115/15	30cm 3-line	100m	High	9
A0272 (228kg)	13/115/15		250m	High	4
A0274 (281kg)	13/115/15	30cm 3-line	250m	High	4
A0393 (97kg)	13/137/15		100m	High	9
A0391 (118kg)	13/137/15	30cm 3-line	100m	High	9
A0394 (241kg)	13/137/15		250m	High	4
A0392 (294kg)	13/137/15	30cm 3-line	250m	High	4
10260 (118kg)	15/150/15		100m	High	9
A0276 (130kg)	15/150/15	30cm 3-line	100m	High	9
A0275 (273kg)	15/150/15		250m	High	4
A0277 (325kg)	15/150/15	30cm 3-line	250m	High	4
A0278 (651kg)	15/150/15	30cm 3-line	500m	High	1
A0395 (343kg)	16/160/15	30cm 3-line	250m	High	4
A0279 (134kg)	19/180/15		100m	High	9

Heavily Galv. Code (Weight)	Product	Roll Length	Tensile Strength	Pallet Qty
STIFF STAY® EXCLUSION FENCE APRON ONLY				
A0247 (29kg)	4/30/15	100m	High	18
HINGED JOINT EXCLUSION FENCE APRON ONLY				
A0310 (39kg)	6/51/15	100m	High	9

FENCING

STIFF STAY

Exclusion Fencing

EXCLUSION FENCING

Narrow 15cm picket spacings for smaller animals and exclusively manufactured by Frauenfelder in Albury NSW, Stiff Stay exclusion fencing features:

Premium Coating & Wire Grade

- Heavily Galvanised
- 2.8mm high tensile top and bottom line wires
- 2.5mm high tensile line wires and 2.5mm vertical stay wires

Continuous Vertical Pickets

- Stiff Stay features continuous vertical pickets which are locked into place to resist sagging & buckling
- Compared to hinged joint fencing, they also provide a better fence over undulating land following the contour of the ground

Optional Pre-attached Hinged Apron

- Pre-attached to the bottom line wire with a hinged joint, the apron is a 300mm section of fence laid on the ground, restricting penetration or digging under the fence
- Exclusion fencing without hinged aprons require the fencing to be forced onto the ground, placing unnecessary stress on your fence posts
- The hinged version is both faster to install and easier on the fence, giving it a longer service life
- Also referred to as a hinged footer

Pre-Stripped Roll

- Stiff Stay has the first two pickets and the last two pickets removed from every roll
- A convenient aid for faster installation around end assemblies - no need to strip picket wires

Tension Crimps

- Stiff Stay line wires include tension crimps that provide a quick visual when judging the correct tension
- When the crimp is half flattened, the tension is generally sufficient; when no crimp can be seen, then the tension in the wire is too high and needs to be reduced

Spacing Chart

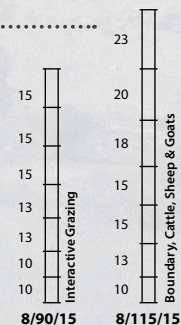

Also available as apron only for fitting to existing fences.

HINGED JOINT

Prefabricated Fencing



HINGED JOINT

Whites Rural Hinged Joint Prefabricated Farm Fencing is made to the highest standards, exclusively from Frauenfelder's Albury plant in regional Australia, using premium grade wire.

- Ideal for stock, boundary and internal fencing
- Flexible knot absorbs stock impact
- 2.50mm high tensile line wires

The strength of the tightly wrapped knot resists livestock pressure while remaining flexible enough to retain its structure. The hinged joint "knot" allows the fence to flex under stock pressure, absorbing the impact of livestock so the fence regains its shape.

Also available in Heavily Galvanised with 2.8mm top and bottom line wires.



FLEXIBLE KNOT

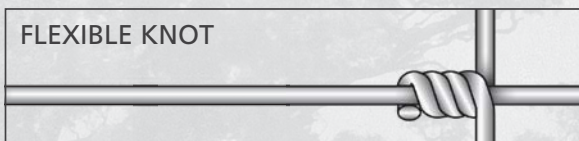

Spacing Chart

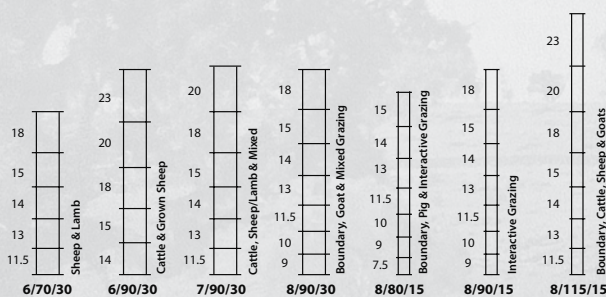

WILD DOG HINGED JOINT

Tight picket spacings protect against feral animals. High tensile 2.0mm line wires and 2.0mm picket wires, 2.5mm top and bottom wires, heavily galvanised to AS4534.

FARMLITE™ HINGED JOINT

Farmlite Hinged Joint is a cost-effective solution for hobby farms and smaller rural properties. Made from 2.00mm standard galvanised wires.



Code	Product	Tensile Strength	Roll Length	Roll Weight	Pallet Qty	Galv. Coating	Line Wire
STANDARD GALVANISED HINGED JOINT							
10291	6/70/30	High	200m	70kg	9	Standard	2.5mm
10292	6/90/30	High	200m	74kg	9	Standard	2.5mm
10293	7/90/30	High	200m	83kg	9	Standard	2.5mm
10294	8/90/30	High	200m	92kg	9	Standard	2.5mm
10295	8/80/15	High	100m	60kg	9	Standard	2.5mm
10298	8/90/15	High	100m	61kg	9	Standard	2.5mm
10299	8/115/15	High	100m	69kg	9	Standard	2.5mm
HEAVY GALVANISED HINGED JOINT							
A0311	6/70/30	High	200m	76kg	9	Heavy	2.5mm
A0312	6/90/30	High	200m	81kg	9	Heavy	2.5mm
A0313	7/90/30	High	200m	90kg	9	Heavy	2.5mm
A0314	8/90/30	High	200m	99kg	9	Heavy	2.5mm
A0315	8/80/15	High	100m	63kg	9	Heavy	2.5mm
A0318	8/90/15	High	100m	67kg	9	Heavy	2.5mm
A0319	8/115/15	High	100m	74kg	9	Heavy	2.5mm

Code	Product	Tensile Strength	Roll Length	Roll Weight	Pallet Qty.	Galv. Coating	Top/Base Wire
HINGED JOINT - WILD DOG							
10287	13/115/15	High	100m	56kg	9	Heavy	2.5mm

Code	Product	Tensile Strength	Roll Length	Roll Weight	Pallet Qty	Galv. Coating	Line Wire
FARMLITE™ HINGED JOINT							
10281	8/90/15	Medium	100m	42kg	9	Standard	2.0mm
10282	8/115/15	Medium	100m	46kg	9	Standard	2.0mm
10272	8/115/15	Medium	50m	24kg	16	Standard	2.0mm



FENCING

HEAVY NETTING

Rural & Boundary Fence



Code	Height	Aperture nom.	Wire Dia. nom.	Roll Length	Roll Weight	Pallet Qty	Galv. Coating
HEAVY NETTING							
10451	30cm	4cm	1.4mm	50m	13kg	48	Heavy
10452	60cm	4cm	1.4mm	50m	26kg	18	Heavy
10454	90cm	4cm	1.4mm	50m	36kg	9	Heavy
10474	90cm	4cm	1.4mm	100m	75kg	9	Heavy
10455	105cm	4cm	1.4mm	50m	42kg	9	Heavy
10475	105cm	4cm	1.4mm	100m	86kg	9	Heavy
10456	120cm	4cm	1.4mm	50m	48kg	9	Heavy
10458	180cm	4cm	1.4mm	50m	74kg	9	Heavy

RURAL NETTING

Whites Rural Heavy Netting is a versatile heavily galvanised netting for rural and heavy duty applications.

- Reverse twist construction
- Double selvedge wires for added strength
- Heavily galvanised

Netting with a 4cm aperture, 1.4mm wire diameter (often referred to as rabbit netting) & is available in varying heights. Suggested uses are:

- 30cm** - reconditioning of existing fences, garden edging
- 60cm** - reconditioning of existing fences, poultry
- 90cm** - rabbit proofing, boundary fencing & tree guards
- 105cm** - rabbit proofing, boundary fencing & tree guards
- 120cm** - boundary and feral fencing, poultry
- 180cm** - feral fencing, poultry and animal enclosures

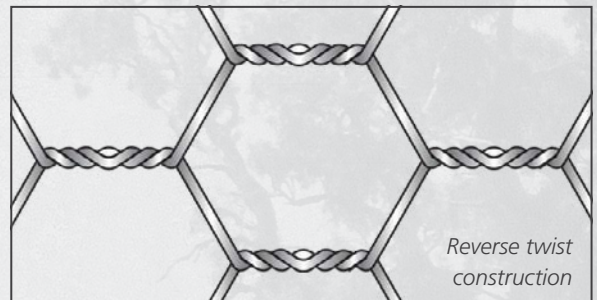

Code	Height	Aperture nom.	Wire Dia. nom.	Roll Length	Roll Weight	Pallet Qty	Galv. Coating
HEAVY NETTING - BOUNDARY							
10653	90cm	5cm	1.6mm	50m	37kg	9	Heavy
10655	120cm	5cm	1.6mm	50m	48kg	9	Heavy
10657	180cm	5cm	1.6mm	50m	71kg	9	Heavy

BOUNDARY NETTING

Whites Rural Heavy Duty Boundary Netting has a 5cm aperture, 1.6mm wire diameter & is available in varying heights. Suggested uses are:

- 90cm** - farm fencing, dogs & tree guards
- 120cm** - feral fencing, animal enclosures & tree guards
- 180cm** - feral fencing, animal enclosures & tennis courts



FARM MESH

Welded Mesh

FARM MESH HEAVY DUTY

Whites Rural Farm Mesh Heavy Duty is a 2.5mm general purpose welded mesh for heavy duty applications.

- Heavy welded construction
- Flush cut edges
- 2.5mm galvanised wire

Whites Rural Farm Mesh can be used for a variety of applications, including:

- Cages and animal enclosures
- Drainage grids
- Fencing and tree guards
- Trailer enclosures

FARM MESH HEAVY DUTY HEAVILY GALVANISED

A heavily galvanised version of the Whites Rural Farm Mesh Heavy Duty.

- Heavily galvanised to AS4534
- 75mm x 50mm aperture
- 2.5mm for heavy duty applications
- Heavy welded construction
- Flush cut edges



DOG MESH HEAVY DUTY

Whites Rural Dog Mesh Heavy Duty is an ideal fencing mesh to keep larger dogs and similar sized animals within a boundary, or out of garden beds and yards.

- Graduated mesh
- Heavy welded construction
- Flush cut edges
- 2.5mm galvanised wire

Line and picket wires have been strengthened for added rigidity. The graduated mesh is available in 120cm & 180cm heights, with smaller apertures at the base to fence puppies and smaller animals.



Code	Height (cm)	Aperture (mm)	Wire Diameter	Roll Length	Roll Weight	Pallet Qty	Galv. Coating
HEAVY DUTY FARM MESH							
21982	90	75 x 50	2.5mm	30m	34kg	9	Standard
21983	120	75 x 50	2.5mm	30m	46kg	9	Standard
21988	180	75 x 50	2.5mm	30m	69kg	9	Standard
21980	90	100 x 100	2.5mm	30m	22kg	16	Standard
21981	120	100 x 100	2.5mm	30m	29kg	16	Standard
21989	180	100 x 100	2.5mm	30m	43kg	9	Standard
HEAVY DUTY FARM MESH - HEAVILY GALVANISED							
22683	90	75 x 50	2.5mm	30m	34kg	9	Heavy
22684	120	75 x 50	2.5mm	30m	46kg	9	Heavy
HEAVY DUTY DOG MESH							
22004	120	Graduated	2.5mm	30m	23kg	16	Standard
22008	180	Graduated	2.5mm	30m	32kg	16	Standard

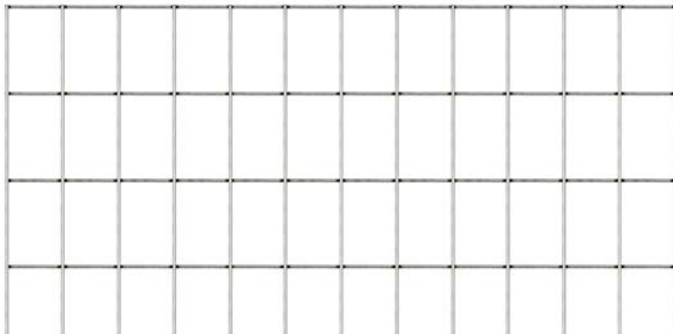

Code	Aperture (mm)	Width (mm)	Length (m)	Weight	Wire Dia. (mm)	Type
SHEEP YARD MESH						
ASYM1	100 x 250	900	6	12.7kg	5	Medium
ASYM2	100 x 250	1100	6	15.3kg	5	Medium
ASYM3	100 x 200	900	6	13.5kg	5	Heavy
ASYM4	100 x 200	1100	6	16.3kg	5	Heavy
ASYM5	100 x 150	900	6	14.9kg	5	X Heavy
ASYM6	100 x 150	1100	6	18kg	5	X Heavy
ASYM7	100 x 250	900	6	15.8kg	5.6	Medium
ASYM8	100 x 250	1100	6	19.1kg	5.6	Medium
ASYM9	150/100 x 250	900	6	10.6kg	4/5	Light

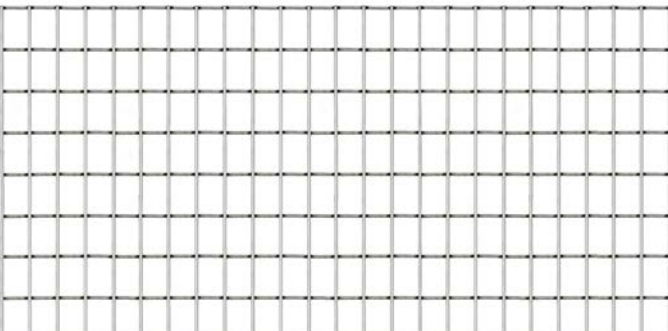

Code	Aperture (mm)	Width (mm)	Length (mm)	Weight	Nom. Wire Dia.
GENERAL PURPOSE MESH PANELS					
21898	25 x 25	1200	2400	7.3kg	2.25mm
21888	25 x 25	1200	2400	7.9kg	2.5mm
21880	50 x 50	1200	2400	5.7kg	3.15mm
21897	75 x 50	1200	2400	7.8kg	3.5mm
21887	75 x 50	1200	2400	9.2kg	4mm
21896	100 x 100	1200	2400	6.1kg	4mm
21886	100 x 100	1200	2400	9kg	5mm

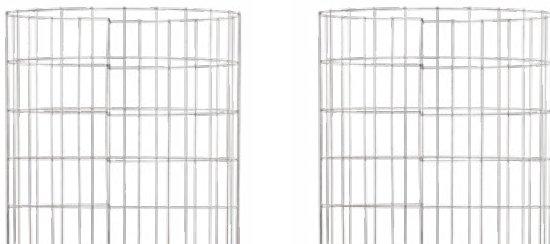

Code	Aperture (mm)	Diameter (mm)	Height (mm)	Length (mm)	Weight	Wire Dia.
TREE GUARD WELD MESH						
ATREE	160 x 100	750	1760	2400	11.2kg	5mm

FENCING

WELDED MESH

Sheep Yard, General & Tree Guards

SHEEP YARD MESH

Whites Rural Sheep Yard Mesh products are manufactured flush with the outside edge of the perimeter wires. Made to the highest standards, exclusively from Frauenfelder's Albury plant in regional Australia, using premium grade wire.

Light: 900mm high - the top two vertical apertures are set at 150mm and the lower six at 100mm. Horizontal 250mm apertures. 5mm line wires, 4mm cross wires.

Medium: 5mm wire with vertical apertures at 100mm and horizontal apertures set at 250mm. Also produced in a 5.6mm wire for special orders.

Heavy: 5mm wire with vertical apertures at 100mm and horizontal apertures set at 200mm.

Extra Heavy: 5mm wire with vertical apertures at 100mm and horizontal apertures set at 150mm.



GENERAL PURPOSE

Whites Rural General Purpose Welded Mesh panels are manufactured in a range of sizes from wire and are produced to Australian Standards. The mesh is finished flush all around for safety and to make joining easy.

Ideal for Animal Enclosures, Cages, Trailer Enclosures, Fencing, Tree Guards, Window Guards, Safety Screens, Drainage Grids, Shelves, Racks & Partitions.

- Flush cut edges on all sides
- Medium tensile galvanised wire

TREE GUARD

Whites Rural Tree Guard is a heavy duty enclosure to protect young trees. Tree Guard is rolled before delivery and arrive ready for installation.



HORTICULTURE

Agri-Wire Trellis & Accessories

AGRI-WIRE® TRELLIS WIRE

Whites Rural Heavily Galvanised Agri-Wire High Tensile Trellis Wire is made to the highest standards, exclusively from Frauenfelder's Albury plant in regional Australia, using premium grade wire.

- Heavily galvanised to last up to 4 times longer
- Produced to the highest tolerance
- Smooth tangle free delivery



Code	Wire	Tensile Strength	Coil Length	Coil Weight	Sling Qty	Coating	Rec. Tension Breaking Strain
AGRI-WIRE® TRELLIS WIRE							
10022	2.00mm	High	2000m	44kg	10	Hvy Gal	1.0kn, 2.7kn
10023	2.65mm	High	1000m	44kg	10	Hvy Gal	2.0kn, 6.0kn
10024	2.85mm	High	1000m	50kg	10	Hvy Gal	2.2kn, 8.3kn
10026	3.15mm	High	1000m	61kg	10	Hvy Gal	3.1kn, 9.4kn



AGRI-WIRE® STRAINER

Whites Rural Agri-Wire Strainer is a specialised strainer for trellis wire in vineyards. Featuring a traditional cam-lock mechanism, the Agri-Wire Strainer's design makes it an easy and effective device for straining wire at the end of trellis.

Suitable for all high tensile wires up to 3.15mm and ideal for use with Whites Rural Agri-Wire Trellis Wire.



Code	Product	Carton Qty
AGRI-WIRE® STRAINER		
12104	Agri-Wire Strainer	40

AGRI-CLIP™

Whites Rural Agri-Clips are specially design to fit most steel fence post. Installed in seconds, proven a fast and easy way to hold and support permanent and semi-permanent trellis wires. Made from tough, durable nylon material.

Suitable for all high tensile wires up to 3.15mm and suits Stockpost and Stockpost XL.



Code	Product	Carton Qty
AGRI-CLIP™		
12317	Agri-Clip V Clips - 50pk	20
12318	Agri-Clip Double C Clips - 50pk	20



FARM GATES

Top Notch & Bar Gates



Nominal Size is the recommended gate opening

Code	Nominal mm (ft)	Actual (mm)	Stay Type	Weight	Weld Mesh (Nom. mm)
TOP NOTCH™ FARM GATES					
13122	875 (2'8")	825	-	8kg	200x100x5
13123	1075 (3'3")	1025	-	9kg	200x100x5
13124	1220 (4'0")	1170	-	10kg	200x100x5
13105	1525 (5'0")	1475	-	13kg	200x100x5
13106	1830 (6'0")	1780	-	14kg	200x100x5
13108	2440 (8'0")	2390	"I"	20kg	200x100x5
13110	3050 (10'0")	3000	"I"	22kg	200x100x5
13112	3660 (12'0")	3610	"I"	26kg	200x100x5
13132	3660 (12'0")	3610	"II"	29kg	200x100x5
13114	4270 (14'0")	4220	"II"	31kg	200x100x5
13116	4880 (16'0")	4830	"II"	36kg	200x100x5



Nominal Size is the recommended gate opening

Code	Nominal mm (ft)	Actual (mm)	Stay Type	Weight	Pipe Mesh (Nom. mm)
5 BAR FARM GATES					
13204	1220 (4'0")	1170	-	13kg	25NB
13205	1525 (5'0")	1475	-	16kg	25NB
13206	1830 (6'0")	1780	-	18kg	25NB
13208	2440 (8'0")	2390	"I"	25kg	25NB
13210	3050 (10'0")	3000	"I"	29kg	25NB
13212	3660 (12'0")	3610	"I"	34kg	25NB
13214	4270 (14'0")	4220	"II"	41kg	25NB
13216	4880 (16'0")	4830	"II"	46kg	25NB

TOP NOTCH™ "I" STAY GATES

Whites Rural Top Notch Gates are manufactured with embedded mesh that sits inside of the gate. Along with end welds that are smooth and flush with the pipe, it makes for a stronger, safer and faster hanging gate.

Inbuilt Strength

Embedded wire mesh increases strength, improves durability.



Edge Protect

Safer for hands and livestock. No sharp edges!



Fast Fit

No need to cut wire mesh. Hinges fit fast!



- All pipe is a uniform 25NB
- 1145mm high, 2400-4800mm wide
- 5mm galvanised wire
- 200mm horizontal x 100mm vertical aperture
- Zinc-based coating completely covers pipe & welds
- Supplied with our "Shut the gate mate!" sign

Whites Rural Farm Gates are made to exacting standards from some of the best materials available, quality tested to ensure trouble-free fencing that is designed to last.

5 BAR FARM GATES

Whites Rural 5 Bar Farm Gates are made stronger for cattle and high pressure livestock situations, featuring horizontal hot-dipped galvanised pipe welded to the outer frame.

- All pipe is a uniform 25NB
- 1145mm high, 1000-4800mm wide
- Zinc-based coating completely covers pipe & welds



FARM GATES

"N" Stay & Collared

"N" STAY FARM GATES

Whites Rural "N" Stay Farm Gates feature 200mm x 75mm mesh size for increased strength and protection. With a diagonal brace running from bottom to top corner, the range is available in left and right hand options (pack of 5 - 3L/2R).

- All pipe is a uniform 25NB
- 1145mm high, 3000-4800mm wide
- 5mm galvanised wire
- 200mm horizontal x 75mm vertical aperture
- Zinc-based coating completely covers pipe & welds
- Supplied with our "Shut the gate mate!" sign

Consistently high quality gates manufactured from high quality galvanised pipe. The pipe is galvanised on the inside as well as the outside to provide maximum protection and a long working life.

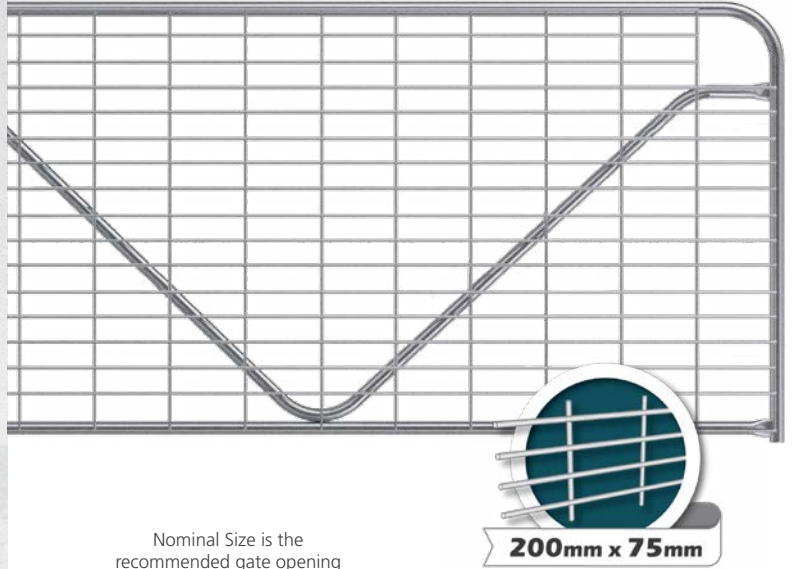
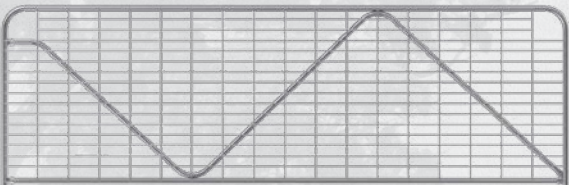

Code	Nominal mm (ft)	Actual (mm)	Stay Type	Weight	Weld Mesh (Nom. mm)
"N" STAY FARM GATES					
13510	3050 (10'0")	3000	"N"	27kg	200x75x5
13512	3660 (12'0")	3610	"N"	30kg	200x75x5
13514	4270 (14'0")	4220	"N"	34kg	200x75x5
13516	4880 (16'0")	4830	"N"	38kg	200x75x5

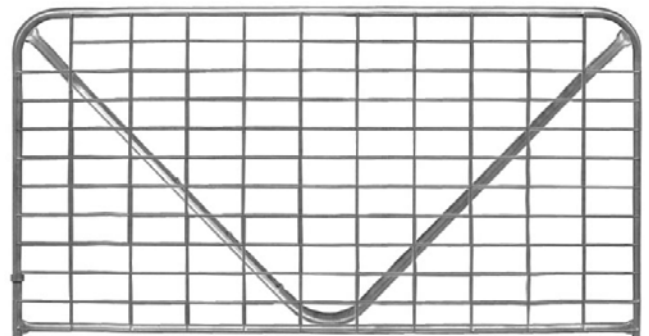

COLLARED FARM GATES

Whites Rural Collared Farm Gates recognise the specific needs of the WA rural market. A range of regular, "I" stay & "V" stay gates has been developed with a pre-fitted collar as distinctly used in Western Australia farming communities.

- All pipe is a uniform 25NB
- 1145mm high, 2400-4800mm wide
- 5mm galvanised wire
- 200mm horizontal x 100mm vertical aperture
- Zinc-based coating completely covers pipe & welds
- Supplied with our "Shut the gate mate!" sign

Code	Nominal mm (ft)	Actual (mm)	Stay Type	Weight	Weld Mesh (Nom. mm)
COLLARED "I" STAY FARM GATES (WA ONLY)					
13403	1075 (3'3")	1025	-	9kg	200x100x5
13404	1220 (4'0")	1170	-	10kg	200x100x5
13405	1525 (5'0")	1475	-	13kg	200x100x5
13406	1830 (6'0")	1780	-	14kg	200x100x5
13408	2440 (8'0")	2390	"I"	20kg	200x100x5
13410	3050 (10'0")	3000	"I"	22kg	200x100x5
13412	3660 (12'0")	3610	"I"	26kg	200x100x5
13414	4270 (14'0")	4220	"II"	31kg	200x100x5
13416	4880 (16'0")	4830	"II"	36kg	200x100x5
COLLARED "V" STAY FARM GATES (WA ONLY)					
13710	3050 (10'0")	3000	"V"	22kg	200x100x5
13712	3660 (12'0")	3610	"V"	26kg	200x100x5
13714	4270 (14'0")	4220	"V"	31kg	200x100x5
13716	4880 (16'0")	4830	"V"	36kg	200x100x5



BLUE LABEL FARM GATES

Whites Rural Blue Label Farm Gates have been manufactured by Frauenfelder in regional Australia since 1948. Years of experience and commitment to the gate industry re-assures farmers and contractors that Frauenfelder gates are the right choice for a high quality gate.

All Blue Label Farm Gates feature:

- 5mm pre-galvanised wire mesh
- 150mm horizontal x 100mm vertical aperture
- 350 grade high tensile 25NB pipe
- Fully welded joints to resist joint cracking
- 1170mm high

Pipe is hot-dipped galvanised to Australian Standards. Available in "I", "II", "III" and "IIII" stays, as well as in "V", "N" and "M" stays, depending on gate length.

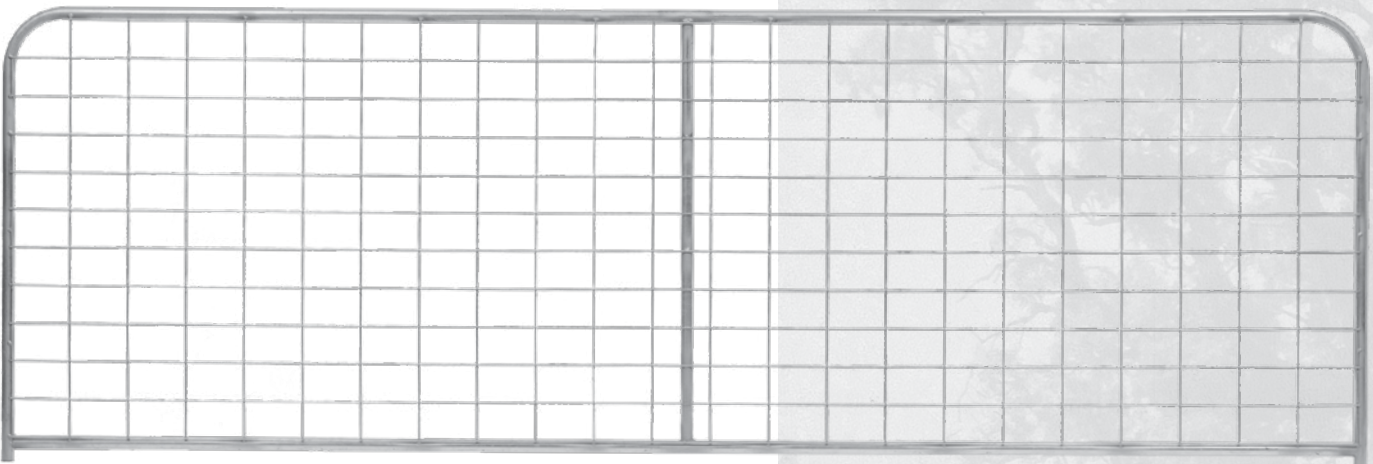
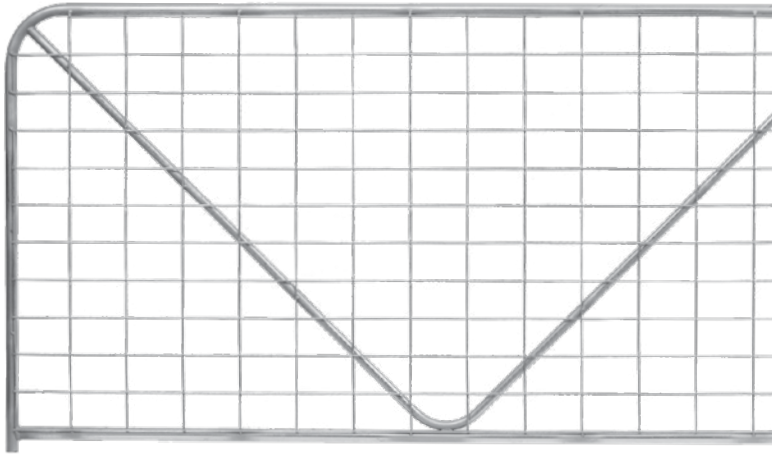

Nominal Size is the recommended gate opening

Upright Code	Stay Type	Weight (kg)	N Stay Code	Stay Type	Weight (kg)	Nominal mm (ft)	Actual (mm)	Mesh (mm)
BLUE LABEL FARM GATES								
AMS03	-	9	-	-	-	915 (3'0")	865	150x100x5
AMS04	-	11	-	-	-	1220 (4'0")	1170	150x100x5
AMS05	"I"	14	-	-	-	1525 (5'0")	1475	150x100x5
AMS06	"I"	16	-	-	-	1830 (6'0")	1780	150x100x5
AMS07	"I"	18	-	-	-	2135 (7'0")	2085	150x100x5
AMS08	"I"	19	AVG08	"V"	22	2440 (8'0")	2390	150x100x5
AMS09	"I"	21	AVG09	"V"	24	2745 (9'0")	2695	150x100x5
AMS10	"I"	23	ANS10	"N"	27	3050 (10'0")	3000	150x100x5
AMS11	"I"	25	ANS11	"N"	29	3350 (11'0")	3300	150x100x5
AMS12	"I"	27	ANS12	"N"	31	3660 (12'0")	3610	150x100x5
AMSD2	"II"	29	-	-	-	3660 (12'0")	3610	150x100x5
AMS13	"II"	31	ANS13	"N"	33	3960 (13'0")	3910	150x100x5
AMS14	"II"	32	ANS14	"N"	36	4270 (14'0")	4220	150x100x5
AMS15	"III"	36	ANS15	"N"	38	4570 (15'0")	4520	150x100x5
AMS16	"III"	38	ANS16	"N"	40	4880 (16'0")	4830	150x100x5
AMS18	"III"	42	ANS18	"N"	44	5485 (18'0")	5435	150x100x5
AMS20	"IIII"	48	ANS20	"M"	52	6095 (20'0")	6045	150x100x5



exclusively manufactured by
frauenfelder
 Your Regional Manufacturer

FARM GATES

Frauenfelder XHD & Stockyard



XHD FARM GATES

Whites Rural Orange Label XHD Farm Gates feature outer frames made with 32NB x 2.6mm high tensile pipe for an extra heavy duty gate. Made in Frauenfelder's Albury plant in regional Australia.

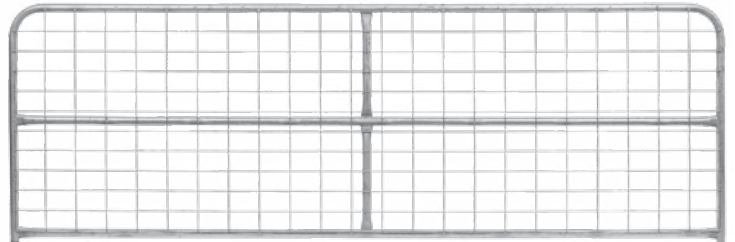

Upright gates available with a cross brace for extra strength
Nominal Size is the recommended gate opening

Code	Nominal mm (ft)	Actual (mm)	Weight	Stay Type	Frame Pipe	Stay Type	Mesh (mm)
XHD N-STAY FARM GATES							
AXV08	2440 (8'0")	2390	23kg	"V"	32NB	25NB	150x100x5
AXN10	3050 (10'0")	3000	33kg	"N"	32NB	25NB	150x100x5
AXN12	3660 (12'0")	3610	40kg	"N"	32NB	25NB	150x100x5
AXN14	4270 (14'0")	4220	47kg	"N"	32NB	25NB	150x100x5
AXN16	4880 (16'0")	4830	53kg	"N"	32NB	25NB	150x100x5
XHD UPRIGHT FARM GATES							
AXM08	2440 (8'0")	2390	26kg	"I"	32NB	32NB	150x100x5
AXM10	3050 (10'0")	3000	31kg	"I"	32NB	32NB	150x100x5
AXM12	3660 (12'0")	3610	35kg	"I"	32NB	32NB	150x100x5
AXMD2	3660 (12'0")	3610	39kg	"II"	32NB	32NB	150x100x5
AXM14	4270 (14'0")	4220	41kg	"II"	32NB	32NB	150x100x5
AXM16	4880 (16'0")	4830	48kg	"III"	32NB	32NB	150x100x5
XHD UPRIGHT FARM GATES - CROSS BRACE							
AXB08	2440 (8'0")	2390	30kg	"I"	32NB	32NB	150x100x5
AXB10	3050 (10'0")	3000	36kg	"I"	32NB	32NB	150x100x5
AXB12	3660 (12'0")	3610	42kg	"I"	32NB	32NB	150x100x5
AXB14	4270 (14'0")	4220	50kg	"II"	32NB	32NB	150x100x5
AXB16	4880 (16'0")	4830	59kg	"III"	32NB	32NB	150x100x5

STOCKYARD FARM GATES

Whites Rural Green Label Stock Yard Farm Gates are the premium gate for cattle and high pressure livestock farming. Made in Frauenfelder's Albury plant in regional Australia since 1948.

Green Label Stock Yard Farm Gates feature:

- 32NB x 2.6mm high tensile pipe frame
- 7 bar gate: 5 x 25NB internal rails
- 20mm through-frame sliding bolt
- 1370mm high

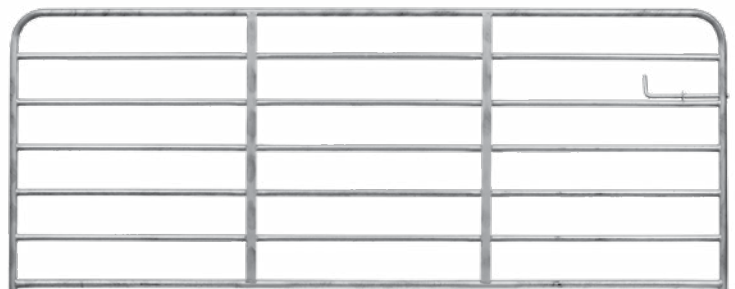

Supplied with a 20mm through-frame sliding bolt
Nominal Size is the recommended gate opening

Code	Nominal mm (ft)	Actual (mm)	Weight	Strap 50x5mm	Frame Pipe	Internal Rails
STOCKYARD FARM GATES						
ABY03	915 (3'0")	865	16kg	-	32NB	25NB
ABY04	1220 (4'0")	1170	21kg	-	32NB	25NB
ABY05	1525 (5'0")	1475	26kg	-	32NB	25NB
ABY06	1830 (6'0")	1780	34kg	1 Strap	32NB	25NB
ABY07	2135 (7'0")	2085	36kg	1 Strap	32NB	25NB
ABY08	2440 (8'0")	2390	39kg	1 Strap	32NB	25NB
ABY09	2745 (9'0")	2695	42kg	1 Strap	32NB	25NB
ABY10	3050 (10'0")	3000	45kg	1 Strap	32NB	25NB
ABY11	3350 (11'0")	3300	50kg	1 Strap	32NB	25NB
ABY12	3660 (12'0")	3610	55kg	2 Straps	32NB	25NB
ABY13	3960 (13'0")	3910	59kg	2 Straps	32NB	25NB
ABY14	4270 (14'0")	4220	63kg	2 Straps	32NB	25NB
ABY15	4570 (15'0")	4520	69kg	3 Straps	32NB	25NB
ABY16	4880 (16'0")	4830	74kg	3 Straps	32NB	25NB

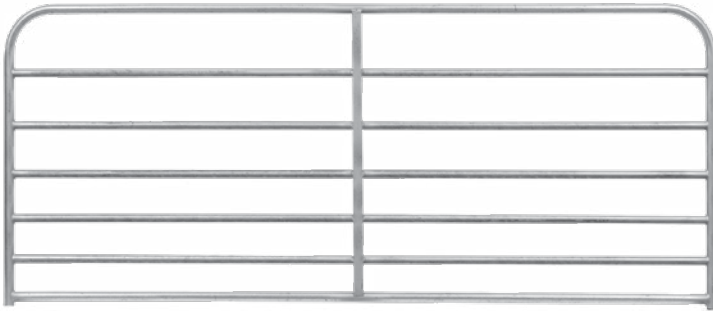

SHEEP YARD FARM GATES

Whites Rural Purple Label Sheep Yard Farm Gates feature:

- 25NB high tensile pipe frame
- 7 bar gate: 5 x 20NB internal rails
- Fully welded joints
- Hot-dipped galvanised pipe

Nominal Size is the recommended gate opening

Code	Nominal mm (ft)	Actual (mm)	Weight	Strap 32x5mm	Height (mm)	Frame Pipe	Internal Rails
SHEEP YARD FARM GATES							
ABS03	915 (3'0")	865	7kg	-	990	25NB	20NB
ABS04	1220 (4'0")	1170	11kg	-	990	25NB	20NB
ABS06	1830 (6'0")	1780	20kg	1 Strap	990	25NB	20NB
ABS08	2440 (8'0")	2390	27kg	1 Strap	990	25NB	20NB
ABS10	3050 (10'0")	3000	34kg	1 Strap	990	25NB	20NB
ABS12	3660 (12'0")	3610	43kg	2 Straps	990	25NB	20NB



exclusively manufactured by
frauenfelder
Your Regional Manufacturer

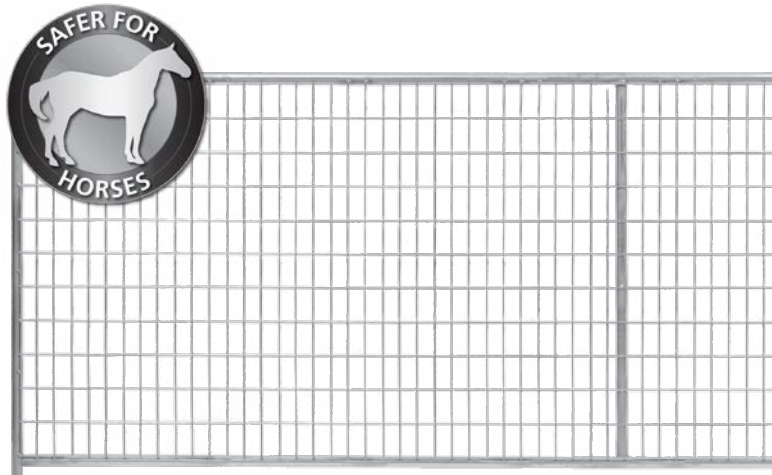

HORSE MESH FARM GATES

Whites Rural White Label Horse Mesh Farm Gates feature a smaller aperture mesh specifically designed to be safer for horses.

- 25NB high tensile pipe frame and braces
- 50mm horizontal x 100mm vertical aperture
- 5mm pre-galvanised wire welded mesh
- Hot-dipped galvanised pipe, fully welded joints

Nominal Size is the recommended gate opening

Code	Nominal mm (ft)	Actual (mm)	Weight	Stay Type	Height (mm)	Mesh (mm)
HORSE MESH FARM GATES - UPRIGHT						
AHI03	915 (3'0")	865	5kg	-	1170	100x50x5
AHI04	1220 (4'0")	1170	6kg	-	1170	100x50x5
AHI06	1830 (6'0")	1780	9kg	"I"	1170	100x50x5
AHI08	2440 (8'0")	2390	12kg	"I"	1170	100x50x5
AHI10	3050 (10'0")	3000	15kg	"I"	1170	100x50x5
AHI12	3660 (12'0")	3610	18kg	"I"	1170	100x50x5
AHI13	3660 (12'0")	3610	18kg	"II"	1170	100x50x5
AHI14	4270 (14'0")	4220	22kg	"II"	1170	100x50x5
AHI16	4880 (16'0")	4830	25kg	"III"	1170	100x50x5
AHI17	5182 (17'0")	5180	33kg	"III"	1170	100x50x5
HORSE MESH FARM GATES - N STAY						
AHN10	3050 (10'0")	3000	15kg	"N"	1170	100x50x5
AHN12	3660 (12'0")	3610	18kg	"N"	1170	100x50x5
AHN14	4270 (14'0")	4220	22kg	"N"	1170	100x50x5
AHN16	4880 (16'0")	4830	24kg	"N"	1170	100x50x5
HORSE MESH FARM GATES - V STAY						
AHV08	2438 (8'0")	2440	15kg	"V"	1170	100x50x5



exclusively manufactured by
frauenfelder
Your Regional Manufacturer

FARM GATES

Ballimore & Feral Gates

BALLIMORE FARM GATES

Whites Rural Ballimore Farm Gates are significantly stronger 'I' stay gates due to their full-length bar and double 'I' stay top. The robust design is also one of the most visually appealing gates available. Made in Albury, Australia.

Ballimore Farm Gates feature:

- Full-length 25NB top bar, double 'I' stay top
- 25NB high tensile pipe frame and brace
- 150mm horizontal x 100mm vertical aperture
- 5mm pre-galvanised wire mesh
- Hot-dipped galvanised pipe to Australian Standards



exclusively manufactured by
frauenfelder
Your Regional Manufacturer

FERAL "I" STAY FARM GATES

Whites Rural Feral Farm Gates are designed to keep stock safe and prevent predators boasting an increased overall height of 1660mm and tighter mesh spacings along the base. Made in Albury, Australia.

Feral Farm Gates feature:

- 1660mm overall height
- 50mm horizontal x 100mm vertical aperture along base
- 25NB high tensile pipe frame and brace
- 150mm horizontal x 100mm vertical aperture top
- 5mm pre-galvanised wire mesh
- Hot-dipped galvanised pipe to Australian Standards

exclusively manufactured by
frauenfelder
Your Regional Manufacturer

CHAIN MESH GATE

Whites Chain Mesh Pedestrian Gate is a popular gate to suit chain wire mesh fences.

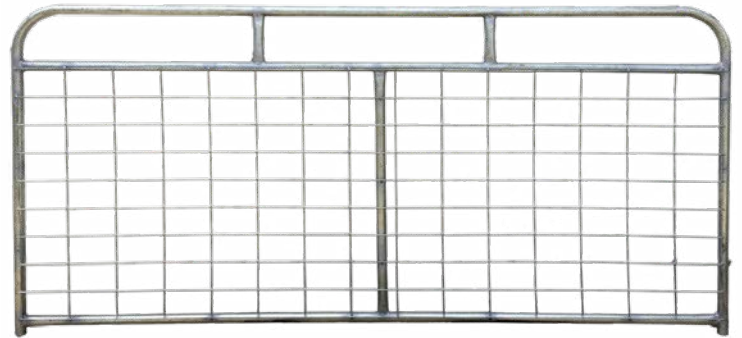

Code	Nominal mm (ft)	Actual (mm)	Stay Type	Weight	Height (mm)	Mesh (mm)
BALLIMORE FARM GATES						
ABA10	3050 (10')	3000	"I"	27kg	1170	150x100x5
ABA12	3660 (12')	3610	"II"	31kg	1170	150x100x5
ABA14	4270 (14')	4220	"II"	36kg	1170	150x100x5
ABA16	4880 (16')	4830	"III"	40kg	1170	150x100x5

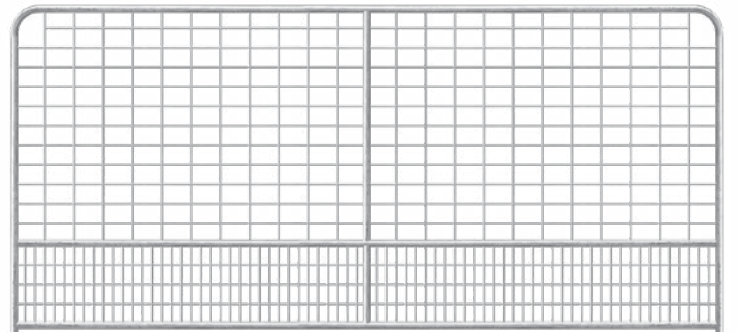

Code	Nominal mm (ft)	Actual (mm)	Stay Type	Weight	Mesh (mm)
FERAL "I" STAY FARM GATES					
13012	3660 (12')	3610	"I"	52kg	150x100x5
13014	4270 (14')	4220	"II"	62kg	150x100x5

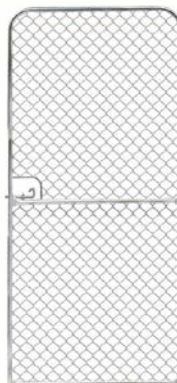

Code	Actual Length x Height (mm)	Weight
CHAIN MESH GATE		
13100	900 x 1800 (3' x 6')	13.5kg

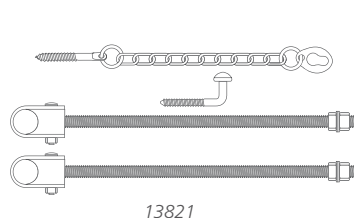
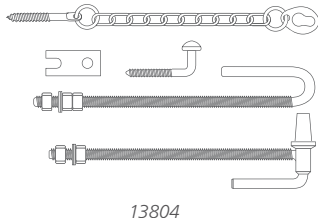
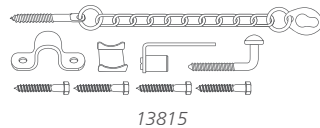
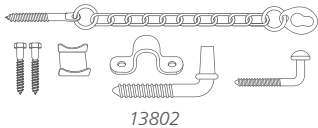
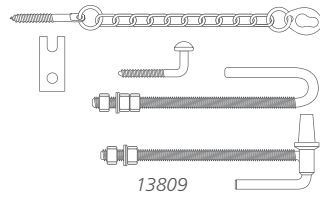
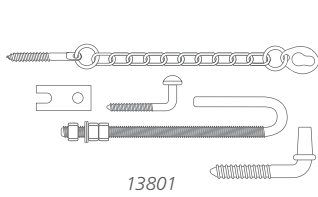
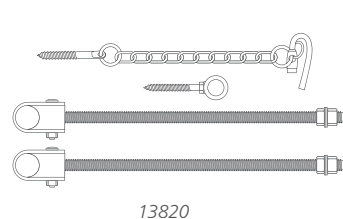
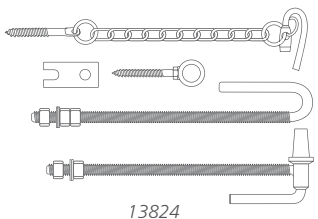
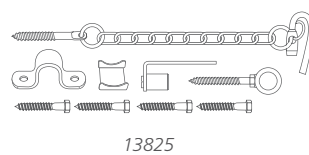
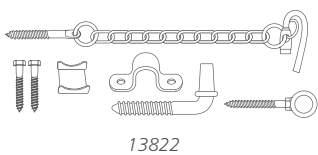
Ring Latch

Drop Latch

GATE FITTING SETS

A wide range of galvanised steel gate fitting sets, all the components included. Hang everything from small pedestrian gates to the largest farm gates.

Available in Drop Latch and Ring Latch:

FG1 General Purpose Pack

- Screw-in 12mm latch and catch (ring latch only)
- Top through-post strap 16mm x 300mm thread length including backing plate
- Screw-in bottom gudgeon

FG2 Economy Pack

- Screw-in 12mm latch and catch
- Top strap assembly
- Screw-in 20mm bottom gudgeon

FG4 Heavy Duty Long Pack

- Screw-in 12mm latch and catch
- Top through-post strap 16mm x 400mm thread length including backing plate
- Bottom through-post gudgeon 16mm x 400mm thread length (all nuts and washers included)

FG9 Heavy Duty Pack

- Screw-in 12mm latch and catch
- Top through-post strap 16mm x 300mm thread length including backing plate
- Bottom through-post gudgeon 16mm x 300mm thread length (all nuts and washers included)

FG15 Multi-Fit Pack

- Screw-in 12mm latch and catch
- Top strap assembly
- Screw-in / weld-on bottom gudgeon

FG20/FG21 Collared Pack (WA only)

- Screw-in 12mm latch and catch
- Top and bottom through-post hinge assemblies 20mm x 400mm thread length with U-shaped hinge (all nuts and washers included)

Ring Latch Code	Drop Latch Code	Product	Pack	Carton Qty	Weight
GATE FITTING SET - RING LATCH & DROP LATCH					
13801	-	General Purpose Pack	FG1	5	1.9kg
13802	13822	Economy Pack	FG2	10	1.6kg
13804	13824	Heavy Duty Long Pack	FG4	5	2.6kg
13809	13829	Heavy Duty Pack	FG9	5	2.5kg
13815	13825	Multi-Fit Pack	FG15	10	1.3kg
13821	13820	Collared Gates (WA only)	FG20	5	2.6kg

GATE FITTINGS

Individual & Specialty Fittings

INDIVIDUAL FITTINGS

Galvanised steel screw-in and weld-on gate fittings.

Latches

Screw-on available in drop and ring types.

Weld-on drop latch suitable for square or round posts. Can be screw-fixed. Low profile safer for animals.

Strap and Gudgeon

Top strap screw-in type.

WG34 gudgeon weld-on type.

G13 gudgeon features long plate - weld-on or screw-in.

Pins and Sleeves

Featuring pin-lock hole for added peace of mind where needed. Simply weld into place.

Each packs contains 2 pairs (2 x pins and 2 x sleeves)

Double Gate Bow

Self-locating latch for double end gates. Suits 25NB gates.

Cattle Yard Slam Latch

Tough and durable weld-on latch and striker plate for cattle yard fencing. Quick access, locks strong.

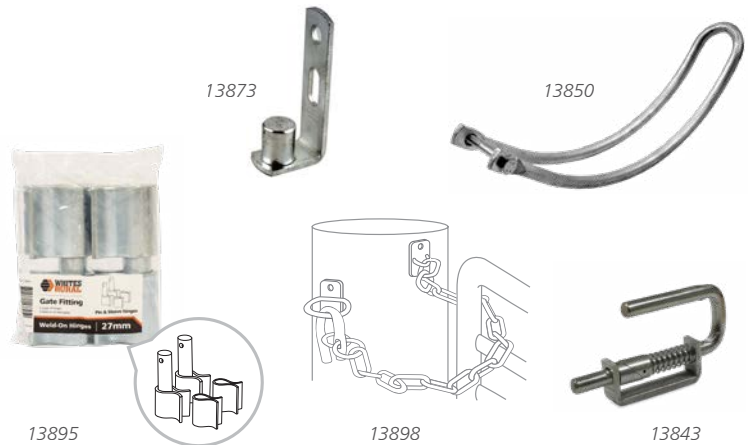

Code	Product	Type
INDIVIDUAL FITTINGS		
13830	Ring Latch & Catch	Screw
13833	Drop Latch & Eyelet	Screw
13862	Top Strap 25mm S3	Screw / Weld-on
13873	Gudgeon 25mm G13	Screw / Weld-on
13875	Gudgeon 25mm WG34	Weld-on
13895	Pins & Sleeves 27mm	Weld-on
13896	Pins & Sleeves 20mm	Weld-on
13897	Pins & Sleeves 16mm	Weld-on
13898	Drop Latch	Weld-on
DOUBLE GATE BOW		
13850	Double Gate Bow	Screw
SLAM LATCH		
13843	Slam Latch 20mm	Weld-on
13844	6mm Striker Plate 75x100mm	Weld-on

SPECIALTY GATE FITTINGS

End Assembly Gate Fittings

Designed for the Stockpost Anchor Post, the fittings attach around the anchor post with no screwing or welding required.

Top strap & gudgeon pack to hinge the gate;
drop latch pack to lock the gate.

Bolt-on Double Gate Latch

Robust fitting suitable for securing 25NB double gates. No need for screwing or welding; just position the latch on the gate frame and tighten the bolt to attach.

Pedestrian Gate Pack

Use with pedestrian gates, the pack features an easy access "D" latch and all the components.

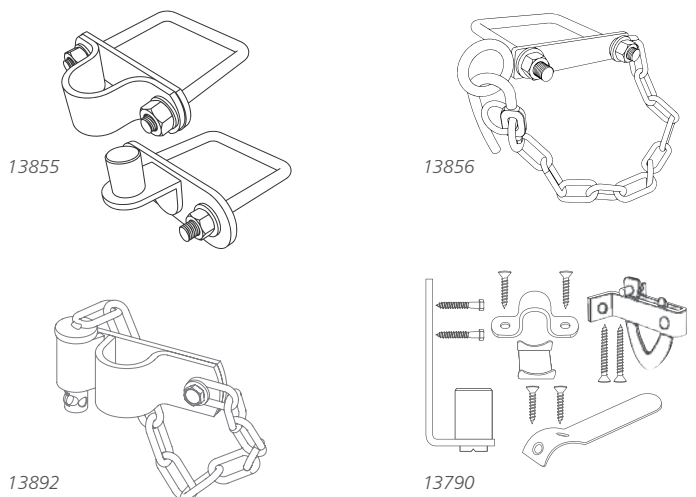

Code	Product	Carton Qty	Weight
SPECIALTY GATE FITTING SETS			
13855	End Assembly Top Strap & Gudgeon	5	1.5kg
13856	End Assembly Drop Latch & Eyelet	5	0.8kg
13892	Bolt-on Double Gate Latch	20	0.7kg
13790	"D" Latch Gate Pack	20	0.7kg



12207



12205



12203

CONTRACTOR GRADE

Contractor "Grip & Lift" Post Lifter

Robustly designed post lifter featuring parallel gripping surface with hardened steel grips. Heavy duty contractor grade construction.

- Hardened steel grips
- Suits most fence posts including Stockpost XL
- Galvanised steel; high tensile bolts

Contractor Post Drivers

Designed with reinforced handles and unique anti-shake handle to reduce vibrations transferred to the operator. Available in two sizes to suit standard posts and larger intermediate posts. Features include:

- Reinforced fully welded handles
- Balanced handles and head, reduces strain
- Anti-vibration collar

Three-Way Wire Spinner

Heavy Duty Three-Way Wire Spinner for smooth payout of plain & barbed wire. Zinc-plated, heavy duty steel construction. Made tough for Australian conditions.

Three different configurations make for an all-in-one tool to make fencing faster:

1. Fence Wire Spinner
Large diameter suits all fence wire types
2. Barbed Wire Spinner
Suitable for all types of barbed wire on reels
3. Mobile Hand-Cart
Turn unit on side for a mobile barbed wire hand-cart

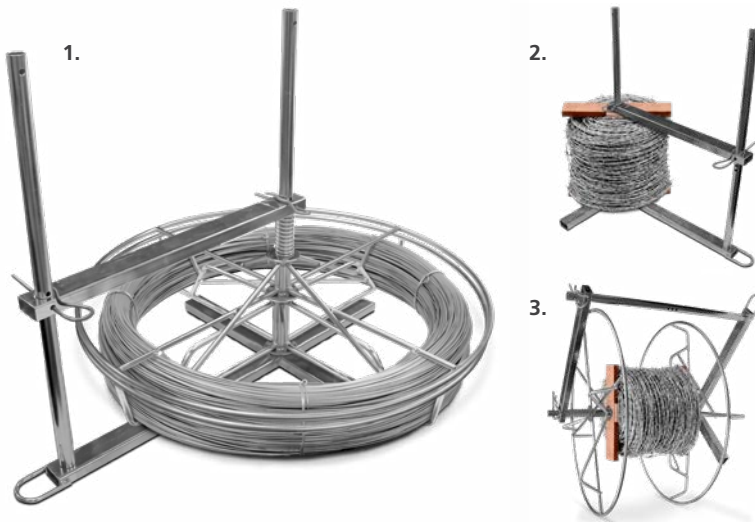

Code	Product	Weight
CONTRACTOR GRADE - LIFTER, DRIVERS & WIRE SPINNER		
12207	Contractor Grade 'Grip & Lift' Post Lifter	5.2kg
12203	Contractor Grade Post Driver	9kg
12205	XL Contractor Grade Post Driver	10kg
12111	Three-Way Wire Spinner	18kg



Code	Product	Weight
STANDARD - LIFTER, DRIVER & WIRE SPINNER		
12200	Post Lifter	8.3kg
12201	800mm Post Driver	6.8kg
12110	Wire Spinner	11.5kg

STANDARD

Whites Rural Standard range of lifter, driver and wire spinner are an economical alternative to the contractor range, available in a durable zinc-plated finish.

Post Lifter

Heavy steel construction. Simply place post in jaw and use the lever action to easily remove steel posts.

Post Driver

Heavy steel construction, weighted balanced head.

Fence Wire Spinner

Central hub is designed for smooth, easy payout, and is adjustable to reduce spin and overrun for faster payout. Includes barbed wire attachment.

STRAINERS

Straining Tools & Wire Strainers



STRAINING TOOLS

Whites Rural offers a wide range of both temporary and permanent wire strainers. Proven designs that are hard wearing and built to last.

Chain Strainers

Removable tool for fence straining, the smooth grip jaws hold all common sizes of fence wire while minimising wire damage.

- Made in New Zealand
- Rugged steel handles, gold passivated finish
- 1.8 metre long chain



12102

Fabricated Farm Fencing Strainers

Used with a chain strainer, it allows for easy straining and installation of fabricated farm fencing. 1.6m - ideal for exclusion fencing.

Length	1.2m	1.6m
Clamping Points	4 wedged pegs	6 wedged pegs
Straining Points	3	5

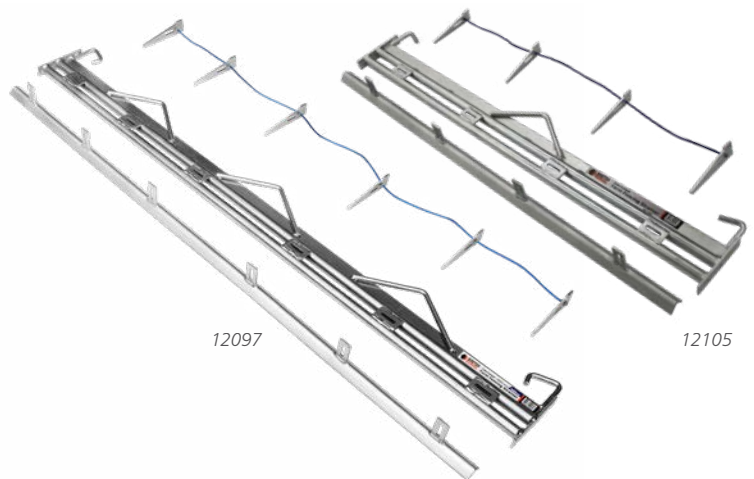

12097

12105

WIRE STRAINERS

Permanent Wire Strainers

The easy solution for fence erecting, wire alignment & fence maintenance fast and easy. Attach to fence line and tighten to strain. Permanent wire strainers stay on the fence line and can be re-tightened over time to prevent wire sag.

- 'Cliplock' Strainers made in New Zealand
- Galvanised steel
- Smooth ratchet action
- Standard and insulated available

Code	Product	Weight
STRAINING TOOLS		
12101	Chain Strainer	3.6kg
12102	Contractor Chain Strainer	3.8kg
12105	Contractor Fabricated Farm Fencing Strainer 1.2m	9.1kg
12097	Contractor Fabricated Farm Fencing Strainer 1.6m	13kg
12109	Replacement Wedge Pack (1.2m)	0.65kg



12106

12500

12501

Code	Product	Pack Qty
PERMANENT WIRE STRAINERS		
12106	CLIPLOCK Permanent Wire Strainer	25
12500	CLIPLOCK Insulated Perm. Wire Strainer - Plastic	20
12501	CLIPLOCK Insulated Perm. Wire Strainer - Porcelain	20
12099	Permanent Wire Strainer	25
12090	Permanent Wire Strainer - Bucket	40

STAPLING

Cordless Impulse Power



ST400i



ST400i Impulse Fencing Staples & Fuel Cell Pack



ST315i



ST315i Impulse Fencing Staples & Fuel Cell Pack

Code	Product	Per Packet	Weight
STOCKade® IMPULSE® POWER STAPLING			
12440	STOCKade ST315i Impulse Power Stapler		6.6kg
12441	STOCKade 33 x 3.15mm Impulse Barbed Staples	2000	6.7kg
12443	STOCKade 40 x 3.15mm Impulse Staples	1800	8.4kg
12445	STOCKade ST400i Impulse Power Stapler		4.2kg
12446	STOCKade 40 x 4.0mm Impulse Barbed Staples	1000	7.75kg
12448	STOCKade 50 x 4.0mm Impulse Barbed Staples	1000	10.2kg
STOCKade® IMPULSE® FENCING ACCESSORIES			
12439	STOCKade ST315i Battery		0.09kg
12449	STOCKade ST400i Battery		0.09kg

STOCKade® Impulse®

STOCKade Impulse power staplers combine faster fencing with hose-free portability in a gas cartridge gun.

ST400i Impulse Power Stapler

The ST400i has outstanding power allowing you to fire up to 650 staples per fuel cell and in conjunction with the 3.7V Li-ion battery, you can fire 3000 barbed, divergent point staples per charge per battery.

The ST400i kit also comes with 2 batteries so you will never run out of power.

- Impulse technology
- Ergonomic design
- Adjustable depth of drive
- Top load magazine
- V-notch guide and sequential trigger system



ST400i staples and fuel cell packs, each pack contains 2 fuel cells, enough for every staple in the pack. Available in 40mm & 50mm, with a 4mm wire diameter.

- Divergent point barbed fencing staple
- Zinc-Aluminium coating for longer life
- Superior driving and improved holding

ST315i Impulse Power Stapler

Driving 3.15mm staples at a rate of up to 2 staples per second, the unit is lightweight and comfortable and there is no need for an air compressor.

ST315i staples and fuel cell packs, each pack contains enough fuel for every staple in the pack. Available in 33mm & 40mm, with a 3.15mm wire diameter.



Exclusively distributed in Australia by Whites Rural

STAPLING

Pneumatic & Manual

STOCKade® Pneumatic

The STOCKade pneumatic power stapling range is designed for faster fencing and reduced manual effort.

The ST400 Pneumatic Power Stapler is engineered specifically for driving heavy-duty barbed fencing staples up to 50mm long.

- Dramatically increases stapling speed and productivity
- Aluminium alloy housing for extreme durability
- Adjustable power for high density timber

The world's only power-driven barbed staple for superior holding power.

- Available in 45mm & 50mm - 4mm wire diameter
- Heavy Zinc-Aluminium Bezinol® 2000 coating
- Divergent point staples



Exclusively distributed in Australia by Whites Rural

FENCING STAPLES

Galvanised double pointed "U" nail for securing wire to timber frames and posts. Plain or barbed staples for added holding power.

- Galvanised for maximum durability
- Razor sharp points for fast, easy driving
- Suitable for securing wire, mesh and netting

Available in Hot-dipped galvanised for longer life.



ST-400

Code	Product	Per Packet	Weight
STOCKade® PNEUMATIC POWER STAPLING			
12430	STOCKade ST400 Power Stapler		6.6kg
12433	STOCKade 45 x 4.0mm Barbed Staples	1200	10.3kg
12434	STOCKade 50 x 4.0mm Barbed Staples	1000	10kg
STOCKade® FENCING ACCESSORIES			
12435	STOCKade Staple Puller		0.8kg



Code	Product	Qty Per Packet	Weight	Carton Qty
GALVANISED STAPLES				
12503	50 x 4.0mm Barbed	50	500g	24
12509	40 x 4.0mm Barbed	52	500g	24
12513	30 x 4.0mm Barbed	65	500g	24
12416	25 x 3.15mm Plain	132	500g	24
12502	50 x 4.0mm Barbed	300	3kg	8
12506	40 x 4.0mm Barbed	315	3kg	8
12512	30 x 4.0mm Barbed	390	3kg	8
12412	25 x 3.15mm Plain	795	3kg	8
12517	50 x 4.0mm Barbed	1500	15kg	1
12518	40 x 4.0mm Barbed	1600	15kg	1
HOT-DIPPED GALVANISED STAPLES				
12504	50 x 4.0mm HDG Barbed	500	5kg	4
12510	40 x 4.0mm HDG Barbed	575	5kg	4
12505	50 x 4.0mm HDG Barbed	1500	15kg	1
12511	40 x 4.0mm HDG Barbed	1600	15kg	1

FASTENERS

Pneumatic & Manual



STOCKade® RINGfast™

The RINGfast pneumatic ring fastening tool quickly and consistently secures ring fasteners.

Faster than manual tools, reliable and relatively effortless, the pneumatic operation produces consistent rings fast, reducing manual effort and improving productivity.

The tool has been designed with an ergonomic grip and is balanced for comfortable operation.

- Quickly and consistently secures ring fasteners
- Reduces manual effort, improves productivity
- Ergonomic and comfortable to operate
- Zinc-Aluminium coating for longer life



JAMBRO® RING FASTENER

Whites Rural exclusively distributes the Jambro Ring Fastener Gun and Clips in Australia. Fast and reliable, this manual gun will fasten to a rate of 25 metres per minute.

The stainless steel jaws and precision body casting ensure quick and easy loading and firing. Use with Jambro high tensile ring clips.

- Faster fencing, 25 metres per minute
- Stainless steel jaws
- High tensile ring fasteners
- Zinc-Aluminium coating for longer life

Code	Product	Per Packet	Weight
STOCKade® RINGFAST™ PNEUMATIC RING FASTENERS			
12308	STOCKade RINGfast Pneumatic Tool (bonus case)		1.5kg
12305	STOCKade RINGfast Ring Fasteners	1000	0.7kg
STOCKade® JAMBRO® RING FASTENERS			
12300	Jambro Ring Fastener Gun		0.4kg
12301	Jambro Standard Ring Fasteners	1000	1kg



WOOL BALE FASTENERS

Super sharp, galvanised and pressed cut to ensure the finest point. Penetrates fabric first time.

Designed to be used in conjunction with Australian Wool Exchange (AWEX) standards.

Code	Product	Per Packet	Weight	Carton Qty
WOOL BALE FASTENERS				
12330	Wool Bale Fasteners	100	500g	24
12331	Wool Bale Fasteners	300	1.5kg	8
12334	Wool Bale Fasteners	700	3.5kg	4
12335	Wool Bale Fasteners		15kg	1

MaxTensor®

Wire Joining, Tensioning & Terminating



MAX Engineering

Exclusively patented system, *MaxTensor's* all metal construction is designed for maximum quality, reliability and ease of use when joining and tensioning wire.

MAX Usability

Ergonomically designed for effortless practicality and long lasting performance, *MaxTensor* makes joining, straining and repairing fences easier.

MAX Reliability

With millions sold globally, *MaxTensor's* patented system is industry tested and proven against the best the world has to offer. Made in the EU to strict specifications.

Exclusively distributed throughout Australia & New Zealand by Whites Rural.



Barbed Wire - MaxTensor
Medium Joiner & Tensioner will fit up to 1.57mm barbed wire.



High Tensile Wire - MaxTensor is specially designed for wire with a high breaking strain.



Electric Fencing - MaxTensor's all metal construction means there is no break in the current.



Zinc Aluminium - MaxTensor's cam wedge provides a strong grip to hold Zn Al coated wire.

All Metal Construction

Joiners & Terminators for fencing wire, horticultural wire & fabricated fence



MaxTensor is a complete range of joiners, tensioners, end post terminators and tensioning tools



12157



12159



12152



12160

12161



Code	Product	Per Packet	Carton Qty
MaxTensor® Wire Joiners & Tensioners			
12157	MaxTensor Medium Joiner - Blister Pack	20	6
12156	MaxTensor Medium Joiner - Contractor Pack	100	2
12155	MaxTensor Medium Joiner - Bulk Pack	250	-
12159	MaxTensor Large Joiner - Blister Pack	10	6
12158	MaxTensor Large Joiner - Bulk Pack	150	-
MaxTensor® Wire Terminators & Tensioners			
12152	MaxTensor Medium Terminator - Blister Pack	10	6
12151	MaxTensor Medium Terminator - Bulk Pack	300	-
MaxTensor® Tensioning Tools (with 5 bonus Medium Joiners)			
12160	MaxTensor Polymer & Steel Core Tensioning Tool		
12161	MaxTensor Heavy Duty Steel Tensioning Tool - Contractor Grade		



Code	Product	Size	Weight	Carton Qty
FENCING PLIERS & TOOLS				
12001	Knipex Professional Wire Cutting Plier	200mm	0.4kg	20
12002	Fencing Pliers - Parrot Beak	250mm	0.6kg	5
12003	Fencing Pliers - Bullnose	250mm	0.6kg	5
12004	Fencing Pliers - Bullnose	300mm	0.7kg	5
12005	Fencer's Tool	-	0.1kg	-



Code	Product	Per Packet	Weight	Carton Qty
FENCE POST CLIPS				
12319	Fence Post Clips (with tool)	250	1.4kg	8
HEAVILY GALVANISED PRE-CUT TIE WIRES				
71541	HG Pre-Cut Tie Wire 3.15mm x 300mm	approx 230	4kg	3
71543	HG Pre-Cut Tie Wire 2.50mm x 300mm	approx 340	4kg	3
HORSE-SAFE POST CAPS				
12348	Horse-Safe Post Caps	-	4.3kg	40
12349	Horse-Safe Post Caps XL	-	3.2kg	20
FENCE POST CAPS				
12322	Post Caps Yellow - 60mm	40	0.8kg	10
STAY PINS				
14340	Stay Pins Galvanised 10 x 300mm	50	9.5kg	



Code	Product	Length	Weight	Carton Qty
FARM PAK™ TIE WIRES				
50223	2.50mm Heavy Galvanised	80m	3kg	5
50224	2.00mm Heavy Galvanised	120m	3kg	5
50225	1.57mm Heavy Galvanised	200m	3kg	5

FENCING PLIERS & TOOL

Genuine Knipex® Quality

Whites Rural distributes Knipex Professional Wire Cutting Plier in Australia. Made in Germany, from heat-treated Cr-V steel, with a tough cutting edge and a comfortable ergonomic design.

Fencing Pliers

Whites Rural multi-use fencing pliers are strong, durable and reliable to make fencing easy. Available in two styles:

Bullnose Pliers - 3 wire cutters

- 2 different wire grips - suits any diameter

Parrot Beak Pliers - Wire cutter, grips and hammer end

- Staple puller 'parrot beak'

Fencer's Tool

Makes tying off fence wire easy. Convenient pocket-size. For use with up to 4.00mm wire diameter.

FENCING ACCESSORIES

Fence Post Clips

Fixes plain or barbed wire to steel fence posts. Easy to use, each pack includes application tool.

Heavily Galvanised Pre-Cut Tie Wires

Easy to work with low tensile, pre-cut 300mm lengths. A great time-saver alternative to cutting longer coils to suit. Heavily galvanised & supplied in re-usable handy packs.

Horse-Safe Fence Post Caps

Hi-visibility and UV-resistant featuring three-slot pattern to hold 5mm hot wire and/or 12-40mm electric tape.

White colour for horse safety. Suit standard 'Y' or larger intermediate posts.

Standard Post Caps

Unique Fin Grip™ system, snugly fits post with no need to tie down. With side holes for fence wire to pass through.

Stay Pins

Hot-dipped galvanised pre-cut 10mm rod lengths ideal for joining timber rails and posts. Long lasting, especially in CCA treated timbers. 300mm length for thicker timber and extra support.

FARM PAK™ TIE WIRES

Whites Rural Farm Pak Tie Wires are wound onto a 'no tangle' dispenser pack for ease of use. The 3kg packs are light enough to carry yet contain sufficient wire for most applications around the farm.

- Heavily Galvanised Wire
- 'No tangle' dispenser
- Easy to handle 3kg packs
- Soft easy to tie



Posts • Fencing • Gates • Tools

Expect More

The market has learnt to expect more from Whites Rural for products and service built around down-to-earth Australian family values.

Our long history of continuous improvement has yielded many new and unique product offerings, always striving to provide greater value to farmers and fencing contractors in the rural market.

Since the launch of Stockpost in 2012, featuring market leading strength, Whites Rural have continued to bring greater value to the Australian market with the introduction of the Australian designed Ute Pack, followed by the ground breaking Stockpost XL and End Assembly ranges.

More recently, a rural partnership with locally-based Frauenfelder has strengthened Whites Rural's connection to rural Australia. Combining over 100 years experience between the two companies, Whites Rural is well poised to deliver more, so you can Expect More.

www.whitesrural.com.au



Whites Group Pty Ltd

ABN 25 001 845 478

SYDNEY
5 Dolerite Way
Pemulwuy, NSW 2145

BRISBANE
Unit 4, 15 Seeana Place
Heathwood, QLD 4110

MELBOURNE
64 Colemans Road
Dandenong South, VIC 3175

TOWNSVILLE
13 Crocodile Crescent
Mt St John, QLD 4818

PERTH
53 Collopy Road
Perth Airport, WA 6105

ADELAIDE
18 Bradford Way
Cavan, SA 5094

Enquiries: 1300 559 732 Fax: 1300 559 762 Email: info@whitesrural.com.au
Specifications referred to in this publication are subject to change, variation and/or improvement without notice.

For the most up-to-date details on all our rural products, visit our website at www.whitesrural.com.au

© WHITES RURAL, STOCKPOST, UTE PACK, STIFF KNOT, STIFF STAY and Agri-Wire are registered trademarks of Whites Group Pty Ltd
™ TOP NOTCH, FARM PAK, FARMLITE, HANDYFENCE, FIN GRIP, AGRI-CLIP and RINGfast are trademarks of Whites Group Pty Ltd

© MaxTensor is a registered trademark of Shiny Works, S.L. © STOCK-ade, Impulse & Jambro are registered trademarks of Paslode Pty Limited

© FRAUENFELDER is a registered trademark of Frauenfelder Gates Pty Limited © Knipex is a registered trademark of KNIPEX-Werk C. Gustav Putsch KG © Bezial is a registered trademark of NV Bekaert SA